

FOREWORD

The SUZUKI GR650 has been developed as a companion motorcycle to the GS-models. It is packed with highly advanced design concepts including a forged one piece crankshaft assembly, a variable mass crankshaft, an air induction system, a full-floater suspension system with a remote hydraulic pre-load adjustment and a fully transistorized ignition system. Combined with precise control and easy handling, the GR650 provides excellent performance and outstanding riding comfort. This service manual has been produced primarily for experienced mechanics whose job is to inspect, adjust, repair and service SUZUKI motorcycles. Apprentice mechanics and do-it-yourself mechanics, will also find this manual an extremely useful guide.

Model GR650 manufactured to standard specifications is the main subject matter of this manual. However, the GR650 machines distributed in your country might differ in minor respects from the standard-specification and, if they do, it is because some minor modifications (which are of no consequence in most cases as far as servicing is concerned) had to be made to comply with the statutory requirements of your country.

This manual contains up-to-date information at the time of its issue. Latermade modifications and changes will be explained to each SUZUKI distributor in respective markets, to whom you are kindly requested to make query about updated information, if any.

SUZUKI MOTOR CO.,LTD.

Administration Department
Overseas Service Division



Quoting, copying or otherwise using any part of this manual without explicit authorization from Suzuki Motor Co., Ltd. is not permitted as all rights to the publication are reserved under copyright law.

VIEW OF SUZUKI GR650



GR650



GR650X

GROUP INDEX

GENERAL INFORMATION

1

**PERIODIC MAINTENANCE AND
TUNE-UP PROCEDURES**

2

SERVICING ENGINE

3

FUEL AND LUBRICATION SYSTEM

4

ELECTRICAL SYSTEM

5

CHASSIS

6

SERVICING INFORMATION

7

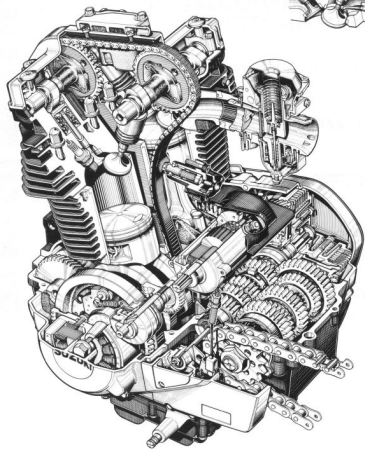

GENERAL INFORMATION

1

CONTENTS

SERIAL NUMBER LOCATIONS	1- 1
FUEL AND OIL RECOMMENDATIONS	1- 1
BREAKING-IN PROCEDURES	1- 2
CYLINDER IDENTIFICATION	1- 2
SPECIAL FEATURES	1- 2
BLOWBY GAS RECYCLING	1- 2
COUNTER BALANCER	1- 3
VARIABLE MASS CRANKSHAFT	1- 8
CAMSHAFT DRIVE CHAIN TENSIONER	1-10
TWIN DOME COMBUSTION CHAMBER	1-11
AIR INDUCTION SYSTEM	1-14
FULL-TRANSISTORIZED IGNITION SYSTEM	1-16
FULL-FLOATING SUSPENSION SYSTEM	1-17
SPECIAL MATERIALS	1-19
PRECAUTIONS AND GENERAL INSTRUCTIONS	1-21
SPECIFICATIONS	1-22

SERIAL NUMBER LOCATIONS

The frame serial number or VIN (Vehicle Identification Number) ① is stamped on the steering head pipe. The engine serial number ② is located on the rear side of the crankcase. These numbers are required especially for registering the machine and ordering spare parts.

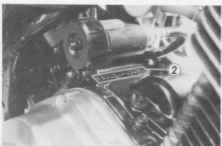

ENGINE OIL

Be sure that the engine oil you use comes under API classification of SE or SF and that its viscosity rating is SAE 10W/40. If SAE 10W/40 motor oil is not available, select the oil viscosity according to the following chart:

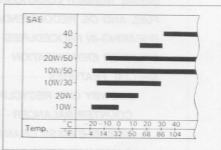

BRAKE FLUID

Specification and classification:	SAEJ1703, DOT3 or DOT4
-----------------------------------	---------------------------

NOTE:

- * Since the brake system of this motorcycle is filled with a glycol-based brake fluid by the manufacturer, do not use or mix different types of fluid such as silicone-based and petroleum-based fluid for refilling the system, otherwise serious damage will result.
- * Do not use any brake fluid taken from old or used or unsealed containers.
- * Never re-use brake fluid left over from the previous servicing and stored for a long period.

FUEL AND OIL RECOMMENDATIONS

FUEL

Gasoline used should be graded 85-95 Octane or higher. An unleaded or low-lead gasoline type is recommended.

FRONT FORK OIL

Use FORK OIL #15.

BREAKING-IN PROCEDURES

During manufacture only the best possible materials are used and all machined parts are finished to a very high standard but it is still necessary to allow the moving parts to "BRAKE-IN" before subjecting the engine to maximum stresses. The future performance and reliability of the engine depends on the care and restraint exercised during its early life. The general rules are as follows:

- Keep to these breaking-in engine speed limits:

Initial	800 km	Below 4,000 r/min
Up to	1,600 km	Below 5,000 r/min
Over	1,600 km	Below 8,500 r/min

- Upon reaching an odometer reading of 1,600 km you can subject the motorcycle to full throttle operation. However, do not exceed 8,500 r/min at any time.
- Do not maintain constant engine speed for an extended time period during any portion of the break-in. Try to vary the throttle position.

CYLINDER IDENTIFICATION

The two cylinders are identified as LEFT-HAND CYLINDER ① and RIGHT-HAND CYLINDER ②.

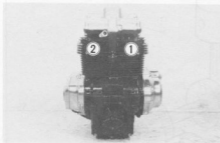

SPECIAL FEATURES

BLOWBY GAS RECYCLING

Blowby gases in the crankcase are constantly drawn into the chain chamber provided in the middle section of the cylinder block. The top section of this chamber is connected with the air chamber assembly through a rubber tube. In the air chamber, the gases merge with incoming air and thus are recycled to the engine through the normal intake system.

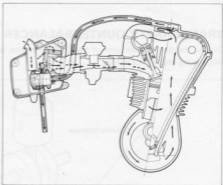
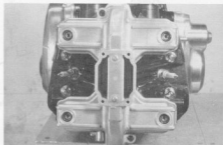

COUNTER BALANCER ENGINE CYCLE

During one engine cycle, power stroke occurs at unequal intervals, that is, intervals of 180° and 540° in terms of crank angle.

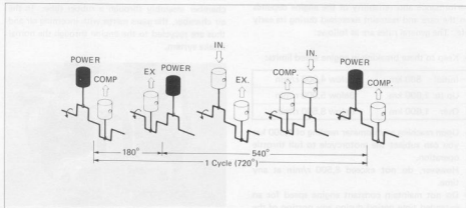

CRANKSHAFT COUNTERBALANCER

One of the distinct features of the GR650 engine is the counterbalancer; it is provided for the purpose of minimizing engine vibration.

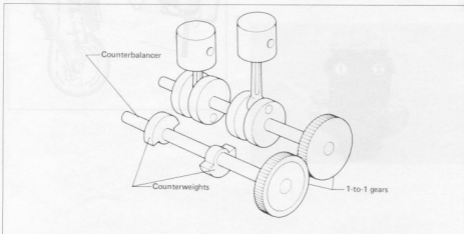

This counterbalancer operates on principles quite different from those of conventional counterbalancing devices often employed in reciprocating engines. For one to understand its operation, one must recall several basic facts of dynamics:

Consider a single rotating shaft having two equal weights attached to it. The weights are 180° apart as is the case with the running parts — including the crankshaft — of the GR650 engine. As the shaft rotates, its ends, supported by bearings, tend to exhibit a grinding motion because of the two centrifugal forces.

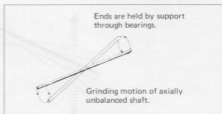
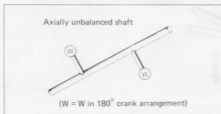

The mass of a crankpin plus its connecting-rod big end, crank arms and others may be regarded similar to such a weight.

The centrifugal force of such a mass (or weight) can be cancelled off by attaching a counterweight 180° opposite to the crankpin. This is done in practically every engine. In this sense, the crankshaft of the GR650 is properly balanced.

There is another kind of vibration-inducing force which the running parts of a cylinder exert to compress and tension, alternately, the connecting rod and thus tend to vibrate the engine as a whole in vertical direction. It is the reciprocating component of the whole mass (inclusive, of course, of the piston, connecting-rod small end and piston rings) that produce this force occurring cyclically in upward and downward directions.

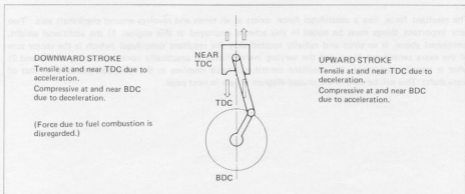

Let a vector represent this vertical force, which increases and decreases alternately as the piston moves up and down between TDC and BDC. (Remember, the length of a vector signifies the magnitude of the force).

Another method is necessary to counter and kill off this force — INERTIA FORCE. If not cancelled off, then the crankshaft system of, say, the GR650 would cause the crankshaft to tend to rock up and down, and this would be felt by the rider as vertical vibrations.

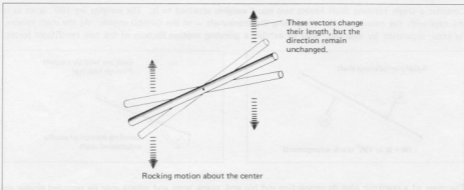

In the case of the GR650 crankshaft system, which is balanced as far as centrifugal forces are concerned, a clever method is used to counter and substantially cancel off the effect of the inertia force. Here's the method:

An additional counterweight is provided for each crankpin, at a position 180° opposite, on the crankshaft to create, intentionally, a centrifugal force. Thus, two extra centrifugal forces occur when the crankshaft rotates in the GR650 engine: their directions are opposite to each other.

Consider this extra centrifugal force for one cylinder. The extra force (existing at all times when the crankshaft is running) and the up-and-down inertia force add to each other and produce a resultant force.

The resultant force, like a centrifugal force, exists at all times and revolves around crankshaft axis. Two very important things must be noted in this scheme employed in this engine: 1) the additional weight, mentioned above, is so sized and radially located that the resultant centrifugal (which is the vector sum of the extra centrifugal force and the varying inertia force) is practically constant in magnitude, and 2) what is equally important, the resultant centrifugal force revolves in the direction opposite to that of crankshaft! This will be seen in the phased diagram shown in next page.



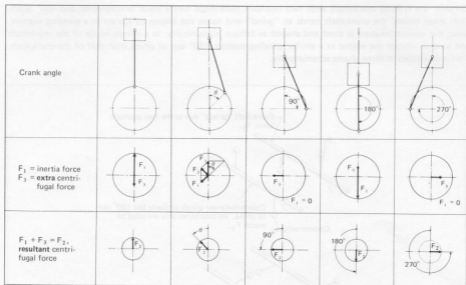

Since the resultant centrifugal force embodies the extra centrifugal force and inertia force at every crank angle, it is obvious that canceling off the resultant force cancels off the two component forces. This canceling is accomplished indirectly in the GR650 by providing a separate unbalanced shaft — the COUNTERBALANCER.

Consider the GR650 crankshaft with two resultant centrifugal forces equal in magnitude and 180° apart. With these forces, the crankshaft tends to "grind" and cause the engine to vibrate in a grinding manner. Now, the counterbalancer is sized and shaped to behave, dynamically, as a mirror image of the crankshaft and tend to vibrate the engine in a similar grinding manner 180° out of phase with that of the crankshaft. This is illustrated in three phases schematically:

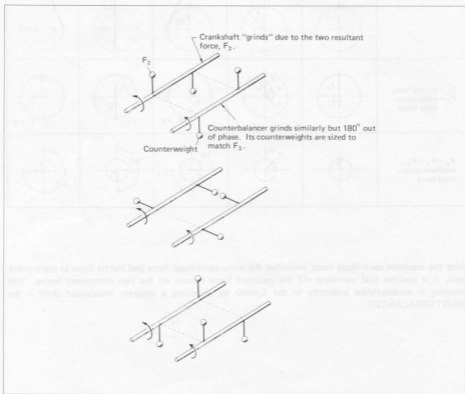

The foregoing explanation is a simplified one and, for sake of brevity, disregards some essentials of dynamics such as revolving speed (on which centrifugal force depends for its magnitude), the breakdown of inertia force into primary force and secondary force, etc. Let it suffice here to add that the crankshaft counterbalancer built into the GR650 engine serves to minimize, not to eliminate, the engine vibration due to mass imbalance in a crankshaft system by intentionally creating special centrifugal forces and by counteracting to the effect (grinding tendency of the engine) of these forces.

VARIABLE MASS CRANKSHAFT

Before explaining the construction of the variable mass crankshaft, consider first the contribution of crankshaft mass to engine performance and feeling.

As can be seen by the chart, a high mass (heavy) crankshaft displays desirable low engine speed characteristics while a low mass (light) crankshaft is more effective at higher engine speeds.

Previously, an engine with a conventional crankshaft had to compromise its low speed characteristics, high speed characteristics, or both. Now, the SUZUKI GR650 with its exclusive variable mass crankshaft makes no compromises.

Engine Speed	Desired Engine Characteristic	Crankshaft Mass	
		High	Low
Low	Easy to ride at low speed	x	
	Smooth, quiet idling	x	
	Fewer gear changes needed	x	
High	Quick acceleration		x
	Good engine braking effect		x
	Improved fuel economy		x

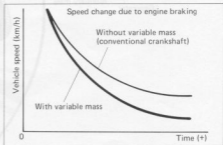
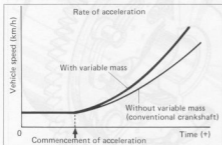
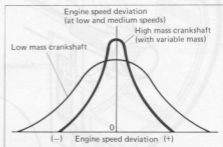
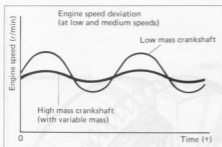

CONSTRUCTION

The variable mass device consists of an auxiliary mass (flywheel) and a centrifugal clutch mounted on the left-hand end of the crankshaft.

At low rpm the centrifugal clutch fixed to the crank, engages the auxiliary mass so that it rotates with the crank. This increases the mass of the crankshaft and smooths out (reduces the magnitude of) the rotational fluctuations.

Above approximately 3,000 r/min the extra mass is unnecessary and undesirable, so the centrifugal clutch disengages the auxiliary mass and it is allowed to spin freely on the crankshaft. This reduction in the crankshaft mass improves acceleration and engine braking performance.

The variable mass crankshaft is another exclusive. But, you expect exclusives from SUZUKI.

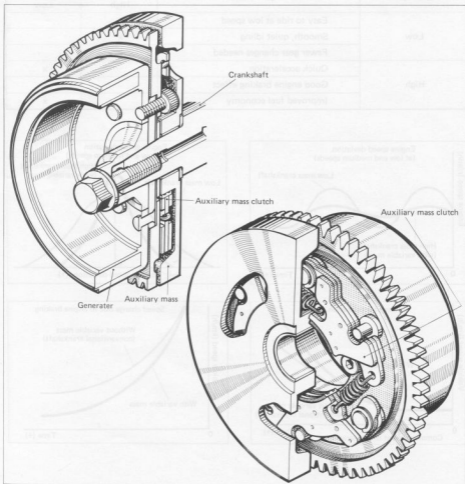

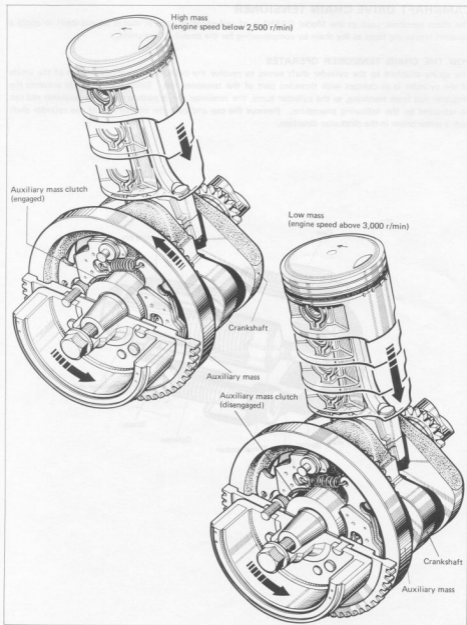

CAMSHAFT DRIVE CHAIN TENSIONER

The chain tensioner used in the Model GR650 is of self-adjusting type in that it adjusts itself to apply a constant tensioning force to the chain by compensating for the stretch of the chain.

HOW THE CHAIN TENSIONER OPERATES

The spring attached to the cylinder shaft serves to revolve the cylinder. The threaded part of the inside of the cylinder is in contact with threaded part of the tensioner rod. Since the rod guide prevents the tensioner rod from revolving, as the cylinder turns, the tensioner rod is pushed out. The tensioner rod can be retracted by the following procedure: Remove the cap and turn the slotted end of the cylinder shaft with a screw driver in the clockwise direction.

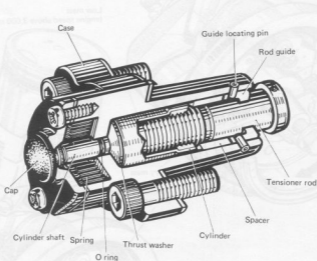

TWIN DOME COMBUSTION CHAMBER

FEATURES OF GR650 ENGINE

The Twin Dome Combustion Chamber for the two-valve engine has been recently developed by SUZUKI Motor Co., Ltd.

This combustion chamber is the very culmination of SUZUKI's research and development work for the ideal combustion chamber for the two-valve engines, based on SUZUKI's experience accumulated through the development of the Type*-TSCC engine.

Any high-performance engine must meet the following requisites given below:

- Good combustion efficiency
- Satisfactory intake and charging efficiency

It is possible to get a high-performance engine only when these two vital factors are combined ideally.

The followings are brief explanation on the configuration and features of the newly-developed combustion chamber which has made it possible to satisfy the above-described requisites in a two-valve engine.

1. Configuration of Combustion Chamber

Fig. 1 shows a hemispheric type combustion chamber, a two-spherical type combustion chamber and a twin dome type combustion chamber, each having the identical valve arrangement and the same compression ratio.

The twin dome configuration means such a shape which would be produced when an egg or a foot ball is cut crosswise.

The following is comparison chart which indicates features of each type of combustion chambers.

Squish area: $C > B > A$

Combustion chamber volume at cylinder head side: $A > B > C$

Height of piston head: $A > B > C$

A: Hemispheric type

B: Two-spherical type

C: Twin dome type

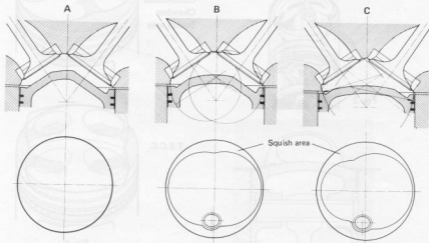

Fig. 1

*JAPAN PATENT NO. 771502

2. Features of SUZUKI Twin Dome Combustion Chamber

1) Swirl

The combustion chamber formed by two domes has been so designed that a swirl can be generated readily because of the walls at both side surfaces, resulting in a very quick combustion speed. (See Fig. 2.)

2) Squish

The mixture will be injected from the squish areas which are formed at both sides at the final stage of the compression stroke. Such squish effect will further accelerate the combustion speed. Figs. 3 and 4 indicate the squish effect of the twin dome combustion chamber and the comparison with the Type *TSCC engine, respectively.

3) Low piston head height

As is described in Fig. 1, the twin dome type combustion chamber has the lowest piston head height. Consequently, such design feature can produce the following essential advantages.

a. The swirl is hardly disturbed.

Acceleration of combustion

b. The heat-receiving area of the piston can be reduced.

Improved durability and prevention of detonation.

The foregoing explains how the newly-developed Twin Dome Combustion Chamber has made it possible to produce a remarkable combustion efficiency by combining the swirl and squish effects and low piston head height.

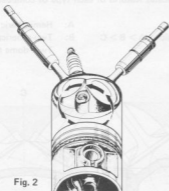

Fig. 2

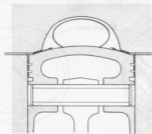
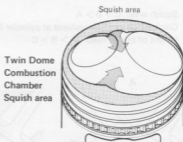

Fig. 3



T.S.C.C.

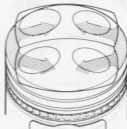

Fig. 4

3. Factors Which Enable Excellent Intake and Charging Efficiency

Figs. 5 and 6 show the flow state of mixture and the change in cross section in a twin dome type combustion chamber and a hemispheric type combustion chamber, respectively.

You will note that the passage area increases sharply at the time of the valve lifting in the case of the hemispheric type combustion chamber. As a result, the flow separation will easily occur. Consequently, the pressure loss increases and the intake mixture volume decreases.

On the other hand, in the case of the twin dome type combustion chamber, the intake mixture volume can be increased by controlling the change in passage area at the time of the valve lifting.

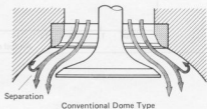
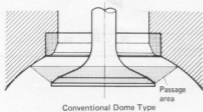
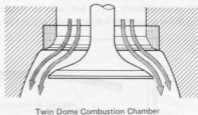
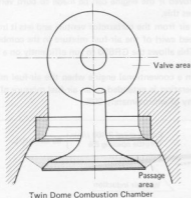

Fig. 5

Fig. 6

AIR INDUCTION SYSTEM

As stated earlier, a truly successful motorcycle must be powerful and fuel efficient in addition to being lightweight. To achieve these goals, again required new technology. Air induction was one successful approach.

An engine's power is roughly proportional to the quantity of air taken in. So, for a given amount of power produced, the leanest possible mixture represents the maximum fuel economy. However, as the mixture is leaned, it becomes less and less able to support combustion and power falls. At the same time fuel consumption actually increases.

From this, it is obvious that fuel economy can be improved if the engine can be made to burn very lean mixtures. The SUZUKI Air Induction System accomplishes this.

As shown in the illustration, the induction system takes air from the carburetor venturi and jets it into the intake port near the intake valve. The resultant high speed swirl of the air-fuel mixture in the combustion chamber makes it easier to ignite and quicker burning. This allows the GR650 to run efficiently on a leaner mixture with a resultant improvement in fuel economy.

The graph shows that combustion cannot be supported in a conventional engine when the air-fuel mixture reaches approximately 16:1. But, with air induction, operation is extended to an air-fuel mixture of 19:1. All else being equal, this is an improvement in fuel economy of approximately 20%.

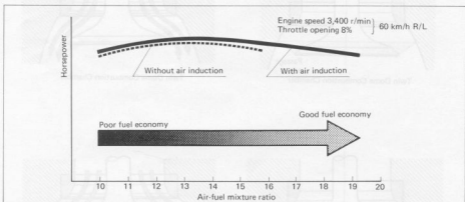

INTAKE TRACT

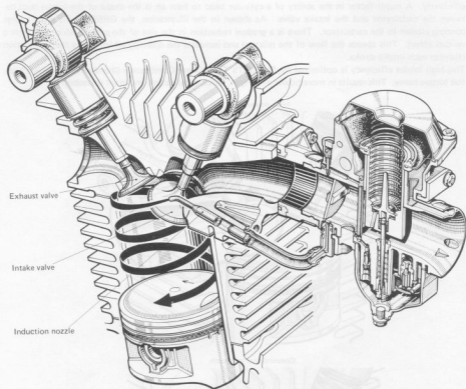

INTAKE TRACT

One of the most important capabilities of a 4-stroke engine is the ability of the cylinder head to flow air efficiently. A major factor in the ability of a cylinder head to flow air is the shape of the intake tract between the carburetor and the intake valve. As shown in the illustration, the GR650 starts with a large opening closest to the carburetor. There is a gradual reduction in the size of the passage which produces a venturi effect. This speeds the flow of the mixture and increases the quantity which enters the combustion chamber each intake stroke.

This high intake efficiency is optimized by SUZUKI's Twin Dome Combustion Chamber to produce a high, flat torque curve. This results in more power at all rpm, quick acceleration and great driveability.

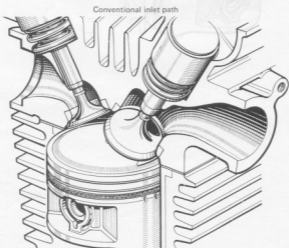
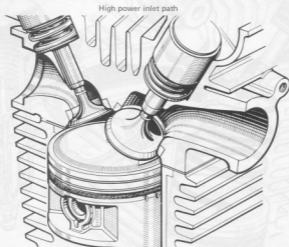

TRANSISTORIZED IGNITION SYSTEM WITH ELECTRONIC ADVANCE

On the Model GR650, the timing advance characteristics of the ignition timing have been changed from the hitherto-employed mechanical timing advance system incorporating an advance governor to an electronic timing advance system.

This system consists of a signal generator, ignitor and ignition coil as shown in Fig. 1.

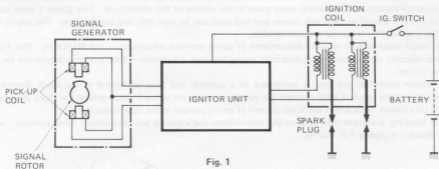

Fig. 1

When the signal rotor is rotated in the system block diagram above, the signal "A" is generated in the pick-up coil. The thus-generated signal will be converted to the signal wave-form "B" at the inside of the ignitor unit and ignition timing is controlled in response to the engine speed as shown in Fig. 2. That is, timing controlled in the ignitor unit becomes ① when the engine speed is lower than N_1 , and it becomes ② when the engine speed is between N_1 and N_2 . The advanced angle when ignited with ② is θ_1 . When higher than N_2 , timing is ③, and the timing does not advance any more. The maximum advanced angle is θ_2 .

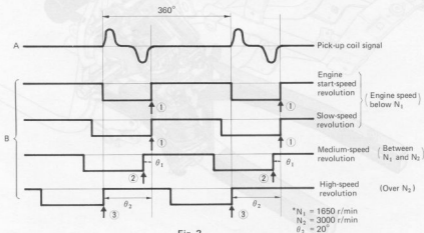

Fig. 2

FULL-FLOATING SUSPENSION SYSTEM

Suzuki's exclusive Full Floater rear suspension has been acclaimed the best. Its dominance on motocross and roadrace tracks around the world has proven it. The Full Floater is a remarkable step forward in suspension technology. It is compact and lightweight with the majority of its weight low and near the motorcycle's center of gravity. Its geometry is such that it is responsive to small bumps and road irregularities, yet it will soak up vicious pot holes and ledges without bottoming out. Shock absorber control is superior for stable handling under all conditions.

The Full Floater of the GR650 has also been designed with the single shock absorber mounted lower than conventional motorcycles, providing more space in the middle of the motorcycle. This allows a lower seat height (only 770 mm) and the side covers and fuel tank can be kept slim and comfortable. This results in a riding position that is natural and comfortable.

Some single shock designs sacrifice convenience of spring pre-load adjustment – not SUZUKI's. This Full Floater features remote controlled hydraulic spring pre-load adjustment. This is a long description for a simple device.

The remote controlled pre-load is comprised of a subtank and hose connected to the shock absorber. Rotating an easily reached knob changes the volume of oil in the subtank which acts on the shock absorber spring via a piston. This allows quick adjustment of spring preload to the rider's requirements.

Stable handling, a smooth ride, light weight, convenience and a natural and comfortable riding position – all with Suzuki's exclusive Full Floater.

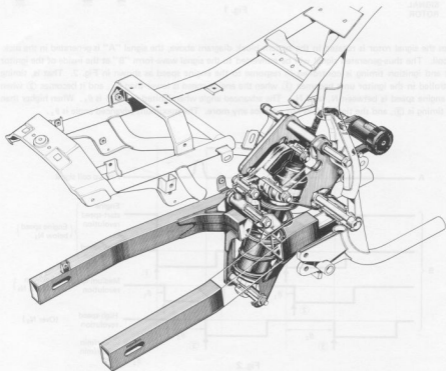

SPECIAL MATERIALS

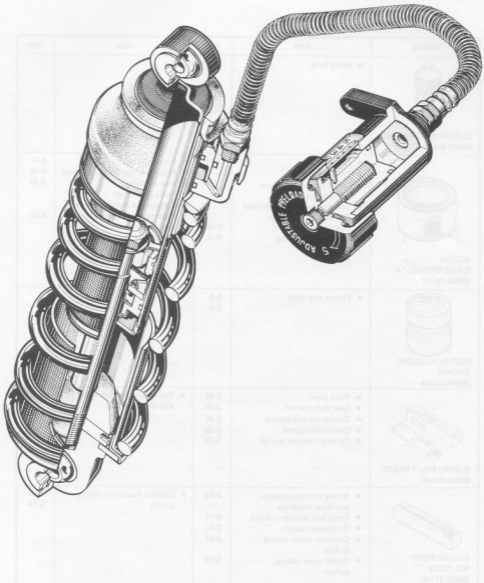

The following table shows the special materials used in the construction of the 5000 Series and should be used as a guide for the selection of materials. The following table shows the special materials used in the construction of the 5000 Series and should be used as a guide for the selection of materials. The following table shows the special materials used in the construction of the 5000 Series and should be used as a guide for the selection of materials.







Part No.	Description	Material
5000-0100	Adjustable Preload	Steel
5000-0101	Washer	Steel
5000-0102	Nut	Steel
5000-0103	Bolt	Steel
5000-0104	Washer	Steel
5000-0105	Nut	Steel
5000-0106	Bolt	Steel
5000-0107	Washer	Steel
5000-0108	Nut	Steel
5000-0109	Bolt	Steel
5000-0110	Washer	Steel
5000-0111	Nut	Steel
5000-0112	Bolt	Steel
5000-0113	Washer	Steel
5000-0114	Nut	Steel
5000-0115	Bolt	Steel
5000-0116	Washer	Steel
5000-0117	Nut	Steel
5000-0118	Bolt	Steel
5000-0119	Washer	Steel
5000-0120	Nut	Steel
5000-0121	Bolt	Steel
5000-0122	Washer	Steel
5000-0123	Nut	Steel
5000-0124	Bolt	Steel
5000-0125	Washer	Steel
5000-0126	Nut	Steel
5000-0127	Bolt	Steel
5000-0128	Washer	Steel
5000-0129	Nut	Steel
5000-0130	Bolt	Steel
5000-0131	Washer	Steel
5000-0132	Nut	Steel
5000-0133	Bolt	Steel
5000-0134	Washer	Steel
5000-0135	Nut	Steel
5000-0136	Bolt	Steel
5000-0137	Washer	Steel
5000-0138	Nut	Steel
5000-0139	Bolt	Steel
5000-0140	Washer	Steel
5000-0141	Nut	Steel
5000-0142	Bolt	Steel
5000-0143	Washer	Steel
5000-0144	Nut	Steel
5000-0145	Bolt	Steel
5000-0146	Washer	Steel
5000-0147	Nut	Steel
5000-0148	Bolt	Steel
5000-0149	Washer	Steel
5000-0150	Nut	Steel
5000-0151	Bolt	Steel
5000-0152	Washer	Steel
5000-0153	Nut	Steel
5000-0154	Bolt	Steel
5000-0155	Washer	Steel
5000-0156	Nut	Steel
5000-0157	Bolt	Steel
5000-0158	Washer	Steel
5000-0159	Nut	Steel
5000-0160	Bolt	Steel
5000-0161	Washer	Steel
5000-0162	Nut	Steel
5000-0163	Bolt	Steel
5000-0164	Washer	Steel
5000-0165	Nut	Steel
5000-0166	Bolt	Steel
5000-0167	Washer	Steel
5000-0168	Nut	Steel
5000-0169	Bolt	Steel
5000-0170	Washer	Steel
5000-0171	Nut	Steel
5000-0172	Bolt	Steel
5000-0173	Washer	Steel
5000-0174	Nut	Steel
5000-0175	Bolt	Steel
5000-0176	Washer	Steel
5000-0177	Nut	Steel
5000-0178	Bolt	Steel
5000-0179	Washer	Steel
5000-0180	Nut	Steel
5000-0181	Bolt	Steel
5000-0182	Washer	Steel
5000-0183	Nut	Steel
5000-0184	Bolt	Steel
5000-0185	Washer	Steel
5000-0186	Nut	Steel
5000-0187	Bolt	Steel
5000-0188	Washer	Steel
5000-0189	Nut	Steel
5000-0190	Bolt	Steel
5000-0191	Washer	Steel
5000-0192	Nut	Steel
5000-0193	Bolt	Steel
5000-0194	Washer	Steel
5000-0195	Nut	Steel
5000-0196	Bolt	Steel
5000-0197	Washer	Steel
5000-0198	Nut	Steel
5000-0199	Bolt	Steel
5000-0200	Washer	Steel

SPECIAL MATERIALS

The materials listed below are needed for maintenance work on the GR650, and should be kept on hand for ready use. They supplement such standard materials as cleaning fluids, lubricants, emery cloth and the like. How to use them and where to use them are described in the text of this manual.

Material	Item	Page	Item	Page
 SUZUKI BRAKE FLUID 99000-23021 (0.5L)	<ul style="list-style-type: none"> ● Brake fluid 			
 SUZUKI SUPER GREASE "A" 99000-25010	<ul style="list-style-type: none"> ● Oil seals ● Throttle grip ● Cables (speedometer and tachometer) ● Gearshift lever mounting boss ● Gearshift lever linkage ● Cushion lever bearing ● Cushion rod bearing 	3-51 6-48 6-48	<ul style="list-style-type: none"> ● Wheel bearings ● Swing arm bearing and dust seal ● Rear brake cam ● Brake pedal shaft ● Centerstand spacer ● Steering stem bearings and races ● Rear shock absorber ● Clutch lever and release 	6-4 6-48 6-39 6-22
 SUZUKI SILICONE GREASE 99000-25100	<ul style="list-style-type: none"> ● Caliper axle shaft 	6-6 6-9		
 SUZUKI MOLY PASTE 99000-25140	<ul style="list-style-type: none"> ● Valve stem ● Cam shaft journal ● Conrod big end bearing ● Crankshaft journal ● Counter balancer journal 	3-29 3-70 3-39 3-56 3-56	<ul style="list-style-type: none"> ● Rear shock absorber upper and lower bearings 	
 SUZUKI BOND NO. 1207B 99000-31140	<ul style="list-style-type: none"> ● Mating surfaces of upper and lower crankcase ● Front fork damper rod bolt ● Oil pressure switch ● Generator cover mating surface ● Clutch cover mating surface 	3-58 6-17 3-65 3-61 3-65	<ul style="list-style-type: none"> ● Cylinder head cover O-ring groove 	2: 4 3-74

Material	Part	Page	Part	Page
 <p>THREAD LOCK SUPER "1333B" 99000-32020</p>	<ul style="list-style-type: none"> • Cam chain guide bolt • Cam chain guide screw • Counterbalancer bolt 	<p>3-33 3-33</p>		
 <p>THREAD LOCK SUPER "1303B" 99000-32030</p>	<ul style="list-style-type: none"> • Countershaft 2nd drive gear • Generator rotor allen bolt • Cam sprocket bolt • Counter balancer drive gear nut • Ring gear securing bolt 	<p>3-50 3-32 3-45 3-46</p>	<ul style="list-style-type: none"> • Oil pump case screw 	<p>3-47</p>
 <p>THREAD LOCK cement 99000-32040</p>	<ul style="list-style-type: none"> • Carburetor set screw • Front fork damper rod bolt • Oil separator plate screw • Engine oil filter cap nut • Engine sprocket spacer inner surface 	<p>4-15 6-17 3-47 2-12 3- 8 3-51</p>		
 <p>THREAD LOCK "1342" 99000-32050</p>	<ul style="list-style-type: none"> • Generator stator securing screw • Generator lead wire guide screw • Countershaft bearing retainer screw • Engine oil pump fitting bolt • Gearshift cam guide screw • Gearshift cam pawl screw 	<p>3-47 3-47 3-62 3-59, 3-63 3-55 3-55</p>	<ul style="list-style-type: none"> • Starter motor securing bolt • Oil sump filter bolt • Starter motor housing securing screw 	<p>3-62 3-59 5-10</p>
 <p>THREAD LOCK SUPER "1305" 99000-32100</p>	<ul style="list-style-type: none"> • Generator rotor bolt 	<p>3-61</p>		

PRECAUTIONS AND GENERAL INSTRUCTIONS

Observe the following items without fail when disassembling and reassembling motorcycles.

- Be sure to replace packings, gaskets, circlips, O-rings and cotter pins with new ones.

CAUTION:

Never reuse a circlip. After a circlip has been removed from a shaft, it should be discarded and a new circlip must be installed.

When installing a new circlip, care must be taken not to expand the end gap larger than required to slip the circlip over the shaft.

After installing a circlip, always insure that it is completely seated in its groove and securely fitted.

- Tighten cylinder head and case bolts and nuts beginning with larger diameter and ending with smaller diameter, and from inside to out-side diagonally, to the specified tightening torque.
- Use special tools where specified.
- Use genuine parts and recommended oils.
- When 2 or more persons work together, pay attention to the safety of each other.
- After the reassembly, check parts for tightness and operation.
- Treat gasoline, which is extremely flammable and highly explosive, with greatest care. Never use gasoline as cleaning solvent.

Warning, Caution and Note are included in this manual occasionally, describing the following contents.

WARNING When personal safety of the rider is involved, disregard of the information could result in injury.

CAUTION For the protection of the motorcycle, the instruction or rule must be strictly adhered to.

NOTE Advice calculated to facilitate the use of the motorcycle is given under this heading.

USE OF GENUINE SUZUKI PARTS

To replace any part of the machine, use a genuine SUZUKI replacement part. Imitation parts or parts supplied from any other source than SUZUKI, if used to replace SUZUKI parts can reduce the machine's performance and, even worse, could induce costly mechanical troubles.



SPECIFICATIONS

DIMENSIONS AND DRY MASS

Overall length	2 150 mm
Overall width	850 mm
Overall height	1 180 mm
Wheelbase	1 430 mm
Ground clearance	150 mm
Dry mass	184 kg GR650 (Cast wheel) 181 kg GR650X (Spoke wheel)

ENGINE

Type	Four-stroke, air-cooled, DOHC
Number of cylinders	2
Bore	77.0 mm
Stroke	70.0 mm
Piston displacement	651 cm ³
Compression ratio	8.7 : 1
Carburetor	MIKUNI BS36SS, twin
Air cleaner	Polyurethane foam element
Starter system	Electric
Lubrication system	Wet sump

TRANSMISSION

Clutch	Wet multi-plate type
Transmission	5-speed constant mesh
Gearshift pattern	1-down, 4-up
Primary reduction	2.250 (72/32)
Final reduction	2.533 (38/15)
Gear ratios, Low	2.846 (37/13)
2nd	1.812 (29/16)
3rd	1.368 (26/19)
4th	1.142 (24/21)
Top	1.000 (22/22)
Drive chain	DAIDO DID50HL or TAKASAGO RK50GO, 106 links

CHASSIS

Front suspension	Telescopic, pneumatic, coil spring oil dampened Only for E28 cast wheel model
Rear suspension	Telescopic, oil dampened The others Full-floating suspension system with remote spring pre-load adjuster

Steering angle	40° (right & left)
Caster	62°30'
Trail	111 mm
Turning radius	2.5 m
Front brake	Disc brake
Rear brake	Internal expanding
Front tire size	100/90-19 57H
Rear tire size	130/90-16 67H
Front fork stroke	140 mm
Rear wheel travel	110 mm
Front tire pressure	200 kPa (2.00 kg/cm ²) (Normal solo riding)
Rear tire pressure	225 kPa (2.25 kg/cm ²) (Normal solo riding)

ELECTRICAL

Ignition type	Transistorized with electronic advance	
Ignition timing	15° B.T.D.C. below at 1 650 r/min and	
	35° B.T.D.C. above at 3 000 r/min	
Spark plug	NGK D8EA or NIPPON DENSO X24ES-U	E1, 24, 25, 34
	NGK DR8ES-L or NIPPON DENSO X24ESR-U The others
Battery	12V 50.4 kC (14 Ah)/10 HR	
Generator	Three-phase A.C. generator	
Fuse	10/10/10/10/15A	
Headlight	12V 60/55W	
Tail/Brake light	12V 8/23W	E1, 6, 24, 28
	12V 5/21W The others
Turn signal light	12V 23W	E1, 6, 24, 28
	12V 21W The others
Speedometer light	12V 1.7W	
Tachometer light	12V 1.7W	
Neutral indicator light	12V 3.4W	
High beam indicator light	12V 1.7W	
Turn signal indicator light	12V 3.4W	
Oil pressure indicator light	12V 3.4W	
Side stand check light	12V 3.4W (Except E16, 18, 22, 26)
Parking or position light	12V 4W (Except E1, 6, 24, 28 spoke wheel model)

CAPACITIES

Fuel tank including reserve	12 L (3.2 US gal)	
	reserve	2.5 L (2.6 US qt)
Engine oil	2 400 ml (2.5 US qt)	
Front fork oil (each leg)	263 ml (8.9 US oz) Only for E28 cast wheel model
	235 ml (7.9 US oz) The others
Front fork air pressure	50 kPa (0.5 kg/cm ²) Only for E28 cast wheel model

* These specifications are subject to change without notice.

PERIODIC MAINTENANCE AND TUNE-UP PROCEDURES

CONTENTS

PERIODIC MAINTENANCE SCHEDULE	2- 1
MAINTENANCE AND TUNE-UP PROCEDURES	2- 3
BATTERY	2- 3
ENGINE BOLTS AND NUTS	2- 4
AIR CLEANER	2- 5
TAPPET CLEARANCE	2- 6
SPARK PLUG	2-10
CARBURETOR	2-11
FUEL LINE	2-12
ENGINE OIL AND OIL FILTER	2-12
CLUTCH	2-13
DRIVE CHAIN	2-13
BRAKES	2-16
TIRES	2-19
STEERING	2-19
FRONT FORK	2-20
CHASSIS BOLTS AND NUTS	2-21

PERIODIC MAINTENANCE SCHEDULE

The chart below lists the recommended intervals for all the required periodic service work necessary to keep the motorcycle operating at peak performance and economy. Mileages are expressed in terms of kilometers and miles.

NOTE:

More frequent servicing may be performed on motorcycles that are used under severe conditions.

PERIODIC MAINTENANCE CHART

ENGINE

Item	Interval			Page
	Initial 1 000 km	Every 5 000 km	Every 10 000 km	
Battery	Inspect	Inspect	—	2-3
Engine bolts and nuts	Inspect	Inspect	—	2-4
Air cleaner		Clean every 3 000 km		2-5
Tappet clearance	Inspect	Inspect	—	2-5
Spark plug	Inspect	Inspect	Replace	2-10
Carburetor	Inspect	Inspect	—	2-11
Fuel lines		Replace every 4 years		2-12
Engine oil and filter	Change	Change	—	2-12
Clutch	Inspect	Inspect	—	2-13

CHASSIS

Item	Interval			Page
	Initial 1 000 km	Every 5 000 km	Every 10 000 km	
Drive chain		Inspect and clean every 1 000 km		2-13
Brakes	Inspect	Inspect	—	2-16
Brake hose		Replace every 4 years		2-16
Brake fluid		Change every 2 years		2-16
Tires	Inspect	Inspect	—	2-19
Steering	Inspect	Inspect	—	2-19
Front fork		Check air pressure every 6 month (only for GR650 E28)		2-20
Front fork oil	Change	—	Change	2-20
Chassis bolts and nuts	Inspect	Inspect	—	2-21

LUBRICATION CHART

The maintenance schedule, which follows, is based on this philosophy. It is timed by odometer indication, and is calculated to achieve the ultimate goal of motorcycle maintenance in the most economical manner.

Item	Interval	
	Initial and every 5 000 km	Every 10 000 km
Throttle cable	Motor oil	—
Throttle grip	—	Grease
Clutch cable	Motor oil	—
Clutch release	—	Grease
Clutch lever	—	Grease or oil
Speedometer cable	—	Grease
Tachometer cable	—	Grease
Drive chain	Motor oil every 1 000 km	
Brake lever	—	Grease or oil
Brake pedal shaft	Grease or oil	—
Brake cam shaft	—	Grease
Rear shock absorber related bearing and bushing	—	Grease
Centerstand spacer	—	Grease
Side stand	Motor oil	—
Steering stem bearings	Grease every 2 years or 20 000 km	
Swing arm bearings		

WARNING:

Be careful not to apply too much grease to the brake cam shaft. If grease gets on the linings, brake slippage will result.

Lubricate exposed parts which are subject to rust, with either motor oil or grease whenever the motorcycle has been operated under wet or rainy conditions.

Before lubricating each part, clean off any rusty spots and wipe off any grease, oil, dirt or grime.

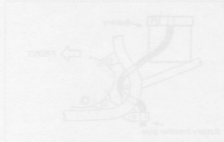

PERIODIC MAINTENANCE AND TUNE-UP PROCEDURES

This section describes the servicing procedures for each item of the Periodic Maintenance requirements.

BATTERY

Inspect Initial 1 000 km and Every 5 000 km

The battery must be removed to check the electrolyte level and specific gravity.

- Remove the seat.
- Remove the battery \ominus and \oplus leads at the battery terminals.
- Remove the battery from the frame.
- Check the electrolyte for level and specific gravity. Add distilled water as necessary, to keep the surface of the electrolyte above the LOWER level line but not above the UPPER level line.

For checking specific gravity, use a hydrometer to determine the charged condition.

09900-28403	Hydrometer
Standard specific gravity	1.28 at 20° C

An S.G. reading of 1.22 (at 20°C) or under means that the battery needs recharging off the machine; take it off and charge it from a recharger. Charging the battery in place can lead to failure of the regulator/rectifier.

- To install the battery, reverse the procedure described above.

CAUTION:

When installing the battery lead wires, fix the \oplus lead first and \ominus lead last.

- Make sure that the battery breather pipe is tightly secured to the battery and is in good condition. Also confirm that it is routed as shown in the figure.

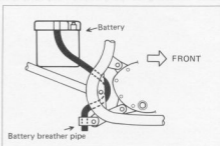
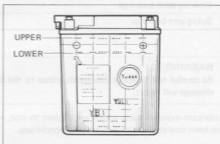
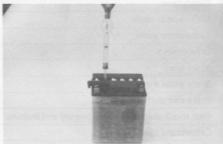
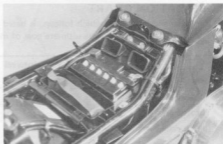

CYLINDER HEAD NUTS AND EXHAUST PIPE BOLTS

Inspect Initial 1 000 km and Every 5 000 km

CYLINDER HEAD

- Remove the fuel tank.
- Remove the cylinder head cover with 6 mm hexagon wrench.
- Loosen the nuts and tighten the eight 10 mm nuts (14 mm wrench) to the specified torque with a torque wrench sequentially in ascending numerical order with the engine cold.

Cylinder head nut	35 – 40 N·m (3.5 – 4.0 kg·m)
-------------------	---------------------------------

- After firmly tightening the 8 nuts, tighten 6 mm bolt (indicated as A) to the torque value below:

Head bolt tightening torque	7 – 11 N·m (0.7 – 1.1 kg·m)
-----------------------------	--------------------------------

- When reinstalling the cylinder head cover, apply SUZUKI Bond No. 1207B to the mating surface.

99000-31140	SUZUKI Bond No. 1207B
-------------	-----------------------

EXHAUST PIPE

- Tighten the muffler mounting bolts, exhaust pipe clamp bolts and muffler connector bolt to the specified torque with a torque wrench.

Exhaust pipe bolt	20 – 25 N·m (2.0 – 2.5 kg·m)
-------------------	---------------------------------

Muffler connector clamp bolt	4 – 7 N·m (0.4 – 0.7 kg·m)
------------------------------	-------------------------------

Muffler mounting bolt	40 – 60 N·m (4.0 – 6.0 kg·m)
-----------------------	---------------------------------

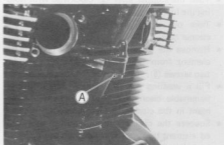
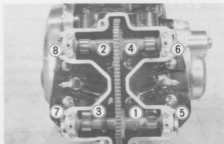

AIR CLEANER ELEMENT

Clean Every 3 000 km

If the air cleaner is clogged with dust, intake resistance will be increased with a resultant decrease in output and an increase in fuel consumption. Check and clean the element in the following manner.

- Remove the left frame cover.
- Remove the four air cleaner case cover screws (1).
- Turn the stopper lever (2) clockwise with holding the bracket.
- Take out air cleaner element (3) from the cleaner case.
- Remove the breather hose (4) and take off the element from the element frame by removing two screws (5).
- Fill a washing pan of a proper size with non-flammable cleaning solvent. Immerse the element in the cleaning solvent and wash it clean.
- Squeeze the cleaning solvent out of the washed element by pressing it between the palms of both hands: do not twist or wring the element or it will develop tears.
- Immerse the element in motor oil, and squeeze the oil out of the element leaving it slightly wet with oil.
- Fit the cleaner element to frame properly.

CAUTION:

- * Before and during the cleaning operation, inspect the element for tears. A torn element must be replaced.
- * Be sure to position the element snugly and correctly, so that no incoming air will bypass it. Remember, rapid wear of piston rings and cylinder bore is often caused by a defective or poorly fitted element.

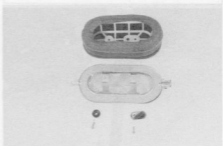
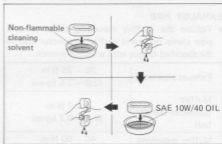
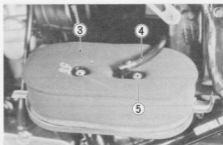
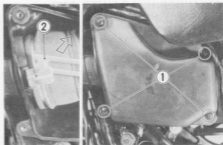

TAPPET CLEARANCE

Inspect Initial 1 000 km and Every 5 000 km

The tappet clearance specification is the same for both intake and exhaust valves. Too small a tappet clearance may reduce the engine power; too large a tappet clearance increases valve noise and hastens valve and seat wear. When the tappets are set to the specified clearance, the engine will run without excessive noise from the valve mechanism and will deliver full power. In this engine, the tappet clearance is increased or decreased by replacing the shim disc, made of a special wear resistant material, fitted to the top of the tappet. The shim discs are easy to remove and refit. Tappet clearance adjustment must be checked and adjusted 1) at the time of periodic inspection, 2) when the valve mechanism is serviced, and 3) when the camshafts are disturbed by removing them for servicing.

Standard tappet clearance (For both intake and exhaust valves)	0.03 – 0.08 mm
---	----------------

NOTE:

- * The clearance specification is for a cold engine. Check it when the engine is cold.
- * To turn the crankshaft for clearance checking, be sure to use a 14-mm wrench and to rotate in the normal running direction. All spark plugs should be removed.

NOTE:

The cam must be at position **A** or **B** to check the tappet clearance or to remove the shim disc. Clearance readings should not be taken with the cam in any other position than these two positions.

- Turn crankshaft to bring the exhaust cam ① of "R" cylinder to this position. In this condition, read the clearance at the exhaust tappets of both cylinders. Use special tool on all tappets.

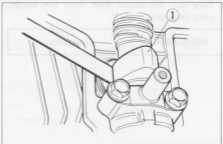
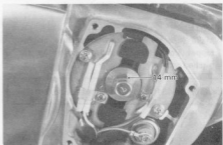
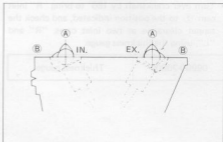

- Turn over crankshaft by 180° to bring "R" inlet cam ② to the position indicated, and check the tappet clearance at two inlet cams, "R" and "L", using the thickness gauge.

09900-20806

Thickness gauge

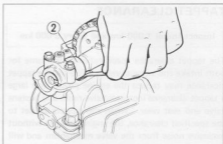

TAPPET CLEARANCE ADJUSTMENT

The clearance is adjusted by replacing the existing tappet shim by a thicker or thinner disc.

- Place a fingertip on the tappet, and turn it in place to bring notch ③ to the position indicated.

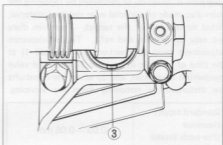

- Using the special tool, push down the tappet.

NOTE:

Make sure the tool exerts pressure on the tappet correctly, as shown, with the tip hitched securely.

09916-64510

Tappet depressor

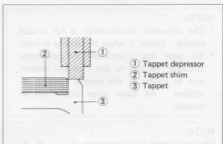

- Take out the tappet shim from the tappet, using the special tool ④.

09916-84510

Tweezers

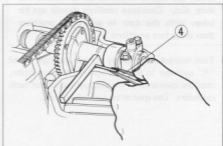

- Check the figures printed on the shim. These figures indicate the thickness of the shim, as illustrated.
- Select a replacement shim that will provide a clearance within the specified range (0.03 – 0.08 mm). For the purpose of this adjustment, a total of 20 sizes of tappet shim are available ranging from 2.15 to 3.10 mm in steps of 0.05 mm. Fit the selected shim to the tappet, with numbers toward tappet. Be sure to check shim size with micrometer to insure its size.

NOTE:

- * Before fitting the tappet shim to the tappet, be sure to apply engine oil to its top and bottom faces.
 - * When seating tappet shim, be sure to face figure printed surface to the tappet.
- After replacing the tappet shim, rotate the engine so that the tappet is depressed fully. This will squeeze out oil trapped between the shim and the tappet that could cause an incorrect measurement, then check the clearance again to confirm that it is within the specified range.
 - When replacing the cylinder head cover, apply SUZUKI Bond No. 1207B to the mating surface lightly.

99000-31140

SUZUKI Bond No. 1207B

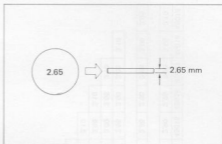

Tappet shim size chart

No.	Thickness (mm)	Part No.
1	2.15	12892-45000
2	2.20	12892-45001
3	2.25	12892-45002
4	2.30	12892-45003
5	2.35	12892-45004
6	2.40	12892-45005
7	2.45	12892-45006
8	2.50	12892-45007
9	2.55	12892-45008
10	2.60	12892-45009
11	2.65	12892-45010
12	2.70	12892-45011
13	2.75	12892-45012
14	2.80	12892-45013
15	2.85	12892-45014
16	2.90	12892-45015
17	2.95	12892-45016
18	3.00	12892-45017
19	3.05	12892-45018
20	3.10	12892-45019

SHIM SELECTION CHART

 PART NUMBER - PREFIX 12892
 PRESENT SHIM SIZE - mm

P/N SUFFIX -	45000	45001	45002	45003	45004	45005	45006	45007	45008	45009	45010	45011	45012	45013	45014	45015	45016	45017	45018	45019
Tapset clearance (mm)	2.15	2.20	2.25	2.30	2.35	2.40	2.45	2.50	2.55	2.60	2.65	2.70	2.75	2.80	2.85	2.90	2.95	3.00	3.05	3.10
0.00-0.02																				
0.03-0.08																				
0.09-0.13																				
0.14-0.18																				
0.19-0.23																				
0.24-0.28																				
0.29-0.33																				
0.34-0.38																				
0.39-0.43																				
0.44-0.48																				
0.49-0.53																				
0.54-0.58																				
0.59-0.63																				
0.64-0.68																				
0.69-0.73																				
0.74-0.78																				
0.79-0.83																				
0.84-0.88																				
0.89-0.93																				
0.94-0.98																				
0.99-1.03																				

SPECIFIED CLEARANCE: NO ADJUSTMENT REQUIRED												
2.50	2.55	2.60	2.65	2.70	2.75	2.80	2.85	2.90	2.95	3.00	3.05	3.10
2.60	2.65	2.70	2.75	2.80	2.85	2.90	2.95	3.00	3.05	3.10		
2.70	2.75	2.80	2.85	2.90	2.95	3.00	3.05	3.10				
2.80	2.85	2.90	2.95	3.00	3.05	3.10						
2.90	2.95	3.00	3.05	3.10								
3.00	3.05	3.10										
3.10												

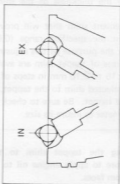

- I. Measure tappet clearance. *ENGINE IS COOL*
- II. Measure present shim size.
- III. Match clearance in vertical column with present shim size in horizontal column.

EXAMPLE

Tappet clearance is — 0.55 mm
 Present shim size — 2.40 mm
 Shim size to be used — 2.90 mm

SPARK PLUG

Inspect Initial 1 000 km and Every 5 000 km
Replace Every 10 000 km

The plug gap is adjusted to 0.6 – 0.7 mm. The gap is correctly adjusted using a thickness gauge (special tool). When carbon is deposited on the spark plug, remove the carbon with a tool with a pointed end. If electrodes are extremely worn or burnt, replace the plug. Also replace the plug if it has a broken insulator, damaged thread, etc.

09930-14530	Universal joint
09930-13210	Socket wrench
09914-24510	T handle
09900-20804	Thickness gauge

NGK D8EA or NIPPON DENSO X24ES-U listed in the table should be used as the standard plug. However, the heat range of the plug should be selected to meet the requirements of speed, actual load, fuel, etc. If the plugs need to be replaced, it is recommended that the standard plugs listed in the table be selected. Remove the plugs and inspect the insulators. Proper heat range would be indicated if both insulators were light brown in color. If they are blackened by carbon, they should be replaced by a hot type NGK D7EA or NIPPON DENSO X22ES-U and if baked white, by NGK D9EA or NIPPON DENSO X27ES-U. Plugs with high heat range number are used for high speed running. These plugs are designed to be sufficiently cooled to prevent overheating and are called cold type plugs.

NOTE:

“R” type spark plug fitted under some of specifications and it means that the resistor is located at the center electrode to prevent radionoise.

NOTE:

To check the spark plugs, first make sure that the fuel tank contains unleaded gasoline, and after a test ride if the plugs are either sooty with carbon or burnt white, replace them altogether.

NOTE:

Confirm the thread size and reach when replacing the plug. If the reach is too short, carbon will be deposited on the screw portion of the plug hole and engine damage may result.

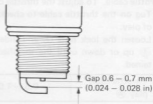

NGK	NIPPON DENSO	REMARKS
D7EA (DR7ES)	X22ES-U (X22ESR-U)	If the standard plug is apt to get wet, replace with this plug. Hot type.
D8EA (DR8ES-L)	X24ES-U (X24ESR-U)	Standard
D9EA (DR9ES)	X27ES-U (X27ESR-U)	If the standard plug is apt to overheat, replace with this plug. Cold type.

CARBURETOR

Inspect Initial 1 000 km and Every 5 000 km

CARBURETOR IDLE RPM

NOTE:

Make this adjustment when the engine is hot.

- Start up the engine and set its speed at anywhere between 1 250 and 1 350 r/min by turning throttle stop screw ①.

Engine idle speed	1 300 ± 50 r/min
-------------------	------------------

CAUTION.

No adjustment except the procedure mentioned above is necessary because calibration is performed by carburetor manufacturer.

THROTTLE CABLE ADJUSTMENT

There should be 0.5 – 1.0 mm play (A) on the throttle cable. To adjust the throttle cable play:

- Tug on the throttle cable to check the amount of play.
- Loosen the lock nuts ② and slide the adjuster ③ up or down until the specified play is obtained.

Throttle cable play (A)	0.5 – 1.0 mm
-------------------------	--------------

- Tighten the lock nuts securely.

CHOKE CABLE ADJUSTMENT

- Loosen the lock nut ④ and turn the adjuster ⑤ to adjust the cable play.

Choke cable play (B)	0.5 – 1.0 mm
----------------------	--------------

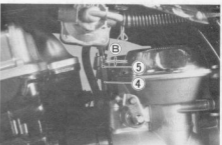
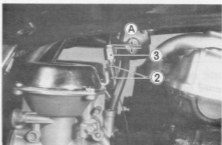

To verify cable travel, pull the cable and measure the play between the adjuster and the lock nut. The play should be 0.5 – 1.0 mm.

FUEL LINE

Replace Every 4 year

ENGINE OIL AND OIL FILTER

Change Initial 1 000 km and Every 5 000 km
--

The oil should be changed while the engine is hot. Oil filter replacement at the above intervals should be done together with engine oil change.

- Keep the motorcycle upright, supported on the center stand.
- Place an oil pan below the engine and drain the oil by removing drain plug ① and filler cap ②.
- Remove three nuts ③ and remove the filter cover.
- Pull out old filter ④, and replace with new one.
- Replace O-ring and filter cover, and secure nuts ③ with applying thread lock cement.

99000-32040	Thread lock cement
-------------	--------------------

- Fit drain plug ① securely, and add fresh oil through the filler. The engine will hold about 2.8 L of oil.
Use API classification of SE or SF oil with SAE 10W/40 viscosity.
- Start up the engine and allow it to run for several seconds at idling speed.
- Turn off the engine and wait about one minute, then check the oil level through the inspection window ⑤. If the level is below mark "F", supply oil to that level.

NECESSARY AMOUNT OF ENGINE OIL

Oil change	2 400 ml
Filter change	2 800 ml
Overhaul engine	3 000 ml

NOTE:

Be sure to take care of O-ring ⑥ to prevent any damage and be sure that filter spring ⑦ is properly in place.

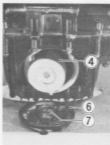
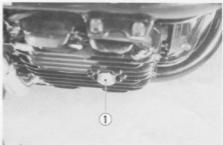

CLUTCH

Inspect Initial 1 000 km and Every 5 000 km

- Remove the clutch inspection cap with 4 mm hexagon wrench.
- Loosen lock nut ① and reposition adjuster ② in place to introduce a necessary amount of play for the clutch lever.

- Loosen lock nut ③, and back adjusting screw ④ away two to three rotations.
- From that position of adjusting screw, slowly run it in until it begins to feel high resistance to turning. From this position, back it away 1/4 – 1/2 rotation, and secure it by tightening lock nut ③.

- Set the adjuster ② to provide a clutch lever play A of 4 mm, and tighten the lock nut ①.

Clutch cable play A

4 mm

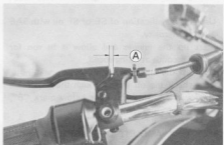
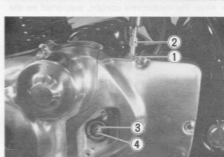
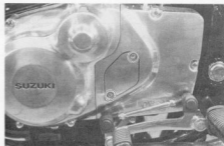

DRIVE CHAIN

Inspect, Clean and Lubricate Every 1 000 km

Visually inspect the drive chain for the possible malconditions listed below.

- Loose pins
- Damaged rollers
- Rusted links
- Twisted or seized links
- Excessive wear

If any defects are found, the drive chain must be replaced.

for DDE-C	adjuster ②
for DDE-E	reposition adjuster ②
for DDE-E	lock nut ③

NOTE:
It is recommended to use the correct size of chain link and rollers. If the wrong size is used, the drive chain will be damaged and the engine will be damaged.

CHECKING

- Loosen axle nut ① after pulling out cotter pin ②.
- Stretch the drive chain fully by tightening the adjusters ③.

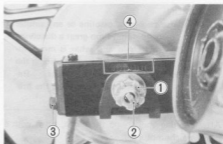

- Remove the chain guard. Count out 21 pins (20-pitch) on the chain and measure the distance between the two. If the distance exceeds following limit, the chain must be replaced.

Service Limit	319.4 mm
---------------	----------

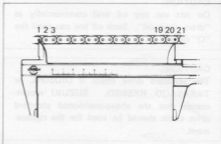
**ADJUSTING**

- Loosen the adjuster ③ until the chain has 10 – 20 mm of sag at the middle between engine and rear sprockets. The mark ④ on both chain adjusters must be at the same position on the scale to ensure that the front and rear wheels are correctly aligned.

Drive chain sag	10 – 20 mm
-----------------	------------

- After adjusting the drive chain, tighten the axle nut ① securely and lock with cotter pin ②. Always use a new cotter pin.

Rear axle nut tightening torque	50 – 80 N·m (5.0 – 8.0 kg·m)
---------------------------------	---------------------------------

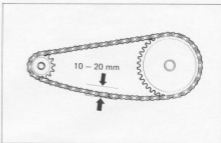
**CLEANING AND LUBRICATION**

Wash the chain with kerosene. If the chain tends to rust faster, the intervals must be shortened.

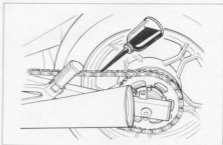

CAUTION:

Do not use trichlene, gasoline or any similar fluids: These fluids have too great a dissolving power for this chain and what is more important, can spoil the "O" rings confining the grease in the bush-to-pin clearance. Remember, high durability comes from the presence of grease in that clearance.

After washing and drying the chain, oil it with a heavy-weight motor oil.

CAUTION:

Do not use any oil sold commercially as "drive chain oil". Such oil too can spoil the "O" rings.

CAUTION:

The standard drive chain is DID50HL or TAKASAGO RK50GO. SUZUKI recommends that the above-mentioned standard drive chain should be used for the replacement.

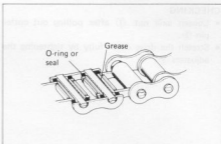

Adjust the chain tension. Loosen the adjuster. Turn the chain the 10-20 mm of sag in the middle between engine and rear sprocket. Tighten the adjuster. The slack must be at the same position on the adjuster to ensure that the front and rear wheels are correctly aligned.

Drive chain sag	10-20 mm
-----------------	----------

After adjusting the drive chain, tighten the nuts and (1) securely and lock with cotter pin (2). Always use a new cotter pin.

Pin nuts lock	30-30 Nm (2.2-3.3 kg-m)
---------------	-------------------------

Wash the chain with kerosene. If the chain looks soiled, the sprockets must be cleaned.

Pin nuts lock	30-30 Nm (2.2-3.3 kg-m)
---------------	-------------------------

Wash the chain with kerosene. If the chain looks soiled, the sprockets must be cleaned.

BRAKES

Inspect Initial 1 000 km and Every 5 000 km
Change fluid Every 2 year.
Replace hose Every 4 year.

BRAKE FLUID LEVEL

- Support the motorcycle on the center stand and place the handlebars straight.
- Check the brake fluid level by observing the lower limit line on the brake fluid reservoir.
- When the level is below the lower limit line, replenish with brake fluid that meets the following specification.

Specification and Classification	SAE J1703, DOT3 or DOT4
----------------------------------	----------------------------

WARNING:

Brake fluid, if it leaks, will interfere with safe running and immediately discolor painted surfaces.

Check the brake hoses for cracks and hose joint for leakage before riding.

CAUTION:

The brake system of this motorcycle is filled with a glycol-based brake fluid. Do not use or mix different types of fluid such as silicone-based and petroleum-based fluid for refilling the system, otherwise serious damage will be caused. Do not use any brake fluid taken from old or used or unsealed containers. Never re-use the brake fluid left over from the last servicing and stored for long periods.

BRAKE LIGHT SWITCHES

Adjust both brake light switches, front and rear, so that the brake light will come on just before a pressure is felt when the brake lever is squeezed, or the brake pedal is depressed.

BRAKE PADS

Wearing condition of brake pads can be checked by observing the brake pad groove ① on the pad. When the wear exceeds the groove, replace the pads with new ones.

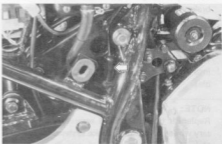
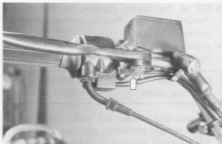

AIR BLEEDING THE BRAKE FLUID CIRCUIT

Air trapped in the fluid circuit acts like a cushion to absorb a large proportion of the pressure developed by the master cylinder and thus interferes with the full braking performance of the caliper brake. The presence of air is indicated by "sponginess" of the brake lever and also by lack of braking force. Considering the danger to which such trapped air exposes the machine and rider, it is essential that, after remounting the brake and restoring the brake system to the normal condition, the brake fluid circuit be purged of air in the following manner:

- Fill up the master cylinder reservoir to the "HIGH" level line. Replace the reservoir cap to prevent entry of dirt.
- Attach a pipe to the caliper bleeder valve, and insert the free end of the pipe into a receptacle.

Bleeder valve tightening torque	6 – 9 N·m (0.6 – 0.9 kg·m)
---------------------------------	-------------------------------

- Squeeze and release the brake lever several times in rapid succession, and squeeze the lever fully without releasing it. Loosen the bleeder valve by turning it a quarter of a turn so that the brake fluid runs into the receptacle, this will remove the tension of the brake lever causing it to touch the handlebar grip. Then, close the valve, pump and squeeze the lever, and open the valve. Repeat this process until the fluid flowing into the receptacle no longer contains air bubbles.

NOTE:

Replenish the brake fluid reservoir as necessary while bleeding the brake system. Make sure that there is always some fluid visible in the reservoir.

- Close the bleeder valve, and disconnect the pipe. Fill the reservoir to the "HIGH" level line.

CAUTION:

Handle the brake fluid with care: the fluid reacts chemically with paint, plastics, rubber materials, etc.

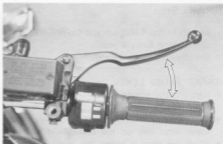

CAUTION:
The brake system of this motorcycle is filled with a special brake fluid. Do not use any other kind of fluid such as mineral oil and petroleum-based fluid for refilling. The special, synthetic brake oil will be used. Do not use any other kind of brake fluid. Do not use any other kind of brake fluid. Do not use any other kind of brake fluid.

BRAKE LIGHT SWITCHES
Adjust both brake light switches. First, set the brake light switch on the right side. The brake light will come on first when a stop is put on the brake lever. It is required to stop the brake light is required.
BRAKE PAD
Wearing condition of brake pads can be checked by observing the brake pad grooves. If so the pad. When the wear reaches the grooves between the pads with new ones.

REAR

Bring the brake pedal to a position about 30 mm below the footrest. This is effected by turning the adjusting bolt ①. Be sure to tighten the lock nut ② securely after setting the bolt.

Brake pedal height	30 mm
--------------------	-------

By repositioning the adjusting nut ③ on the brake rod, set the pedal play to between 20 and 30 mm ④ as measured at pedal tip.

Brake pedal play ④	20 – 30 mm
--------------------	------------

Check to be sure that rear brake light comes on when the pedal is depressed to take up the play.

BRAKE SHOE WEAR

This motorcycle is equipped with a brake lining wear limit indicator on a rear as shown in the Fig. At the condition of normal lining wear, the extension line of the index mark on the brake cam shaft should be within the range embossed on the brake panel with brake on.

To check wear of the brake lining, perform the following steps.

- First check if the brake system is properly adjusted.
- While operating the brake, check to see that the extension line of the index mark is within the range on the brake panel.
- If the index mark is beyond the range as shown in the Fig., the brake shoe assembly should be replaced with a new shoe set.

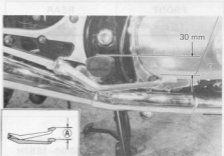
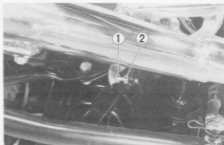

The extension line of the index mark is beyond the range.



TIRES

Inspect Initial 1 000 km and Every 5 000 km

TIRE TREAD CONDITION

Operating the motorcycle with excessively worn tires will decrease riding stability and consequently invite a dangerous situation. It is highly recommended to replace the tire when the remaining depth of tire tread reaches the following specifications.

FRONT	REAR
1.6 mm	2.0 mm

TIRE PRESSURE

If the tire pressure is too high or too low, steering will be adversely affected and tire wear increased. Therefore, maintain the correct tire pressure for good roadability or shorter tire life will result.

CAUTION:

The standard tire fitted on the motorcycle is 100/90–19 57H for front and 130/90–16 67H for rear. The use of a tire other than the standard may cause instability. It is highly recommended to use a SUZUKI Genuine Tire.

STEERING

Inspect Initial 1 000 km and Every 5 000 km

Check that there is no play in the front fork assembly by supporting the machine so that the front wheel is off the ground. With wheel straight ahead, grasp lower fork tubes near the axle and pull forward. If play is found, perform steering bearing adjustment as described on page 6-22 of this manual.

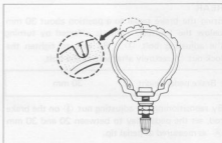

Cold inflation tire pressure is as follows.

	FRONT		REAR	
	kPa	kg/cm ²	kPa	kg/cm ²
Solo riding	200	2.00	225	2.25
Dual riding	200	2.00	250	2.50



FRONT FORK

Inspect Initial 1 000 km and Every 10 000 km
Check air pressure Every 6 month
(only for GR650 E28)
Change fork oil Initial 1 000 km and
Every 10 000 km

Check the front fork air pressure, when the fork is cold, every 6 months by the following manner.

- Place the motorcycle on the center stand and keep the front wheel off the ground.
- Measure the air pressure by placing the pressure gauge on the valve as shown.

Specified air pressure	50 kPa (0.5 kg/cm ²)
------------------------	----------------------------------

- If necessary, use only a hand air pump to raise the front fork air pressure.

NOTE:

- * Just before charging air, confirm that the valve is tight.
- * Try to equalize the air pressure of the two legs, right and left, as closely as possible. The maximum permissible difference is 10 kPa (0.1 kg/cm²).

Inspect the front fork for oil leakage, scoring and scratches on the outer surface of the inner tube every 10 000 km and replace the defective parts, if necessary.

When changing fork oil, refer to page 6-13.



0.2 - 0.1	0.2 - 0.1	Check the fork seal.	2
0.3 - 0.1	0.3 - 0.1	Check the fork seal.	3
0.0 - 0.0	0.0 - 0.0	Check the fork seal.	4
0.0 - 0.0	0.0 - 0.0	Check the fork seal.	5
0.0 - 0.0	0.0 - 0.0	Check the fork seal.	6
0.0 - 0.0	0.0 - 0.0	Check the fork seal.	7
0.0 - 0.0	0.0 - 0.0	Check the fork seal.	8
0.0 - 0.0	0.0 - 0.0	Check the fork seal.	9
0.0 - 0.0	0.0 - 0.0	Check the fork seal.	10
0.0 - 0.0	0.0 - 0.0	Check the fork seal.	11
0.0 - 0.0	0.0 - 0.0	Check the fork seal.	12
0.0 - 0.0	0.0 - 0.0	Check the fork seal.	13
0.0 - 0.0	0.0 - 0.0	Check the fork seal.	14
0.0 - 0.0	0.0 - 0.0	Check the fork seal.	15
0.0 - 0.0	0.0 - 0.0	Check the fork seal.	16
0.0 - 0.0	0.0 - 0.0	Check the fork seal.	17
0.0 - 0.0	0.0 - 0.0	Check the fork seal.	18
0.0 - 0.0	0.0 - 0.0	Check the fork seal.	19
0.0 - 0.0	0.0 - 0.0	Check the fork seal.	20
0.0 - 0.0	0.0 - 0.0	Check the fork seal.	21
0.0 - 0.0	0.0 - 0.0	Check the fork seal.	22
0.0 - 0.0	0.0 - 0.0	Check the fork seal.	23
0.0 - 0.0	0.0 - 0.0	Check the fork seal.	24

CHASSIS BOLTS AND NUTS

Inspect Initial 1 000 km and Every 5 000 km

The bolts and nuts listed hereunder are important safety parts. They must be retightened, as necessary, to the specified torque with a torque wrench. Refer to the next page for position of the following bolts and nuts.

ITEM		N-m	kg-m	
1	Front axle nut	36 – 52	3.6 – 5.2	
2	Front axle holder nut	15 – 25	1.5 – 2.5	
3	Disc plate bolt	15 – 25	1.5 – 2.5	
4	Spoke nipple	4 – 5	0.4 – 0.5	
5	Caliper mounting bolt	25 – 40	2.5 – 4.0	
6	Caliper axle bolt	15 – 20	1.5 – 2.0	
7	Front fork lower clamp bolt	15 – 25	1.5 – 2.5	
8	Front fork upper clamp bolt	20 – 30	2.0 – 3.0	
9	Steering stem nut	40 – 60	4.0 – 6.0	
10	Steering stem clamp bolt	15 – 25	1.5 – 2.5	
11	Steering stem head bolt	20 – 30	2.0 – 3.0	
12	Handlebar clamp bolt	12 – 20	1.2 – 2.0	
13	Brake hose union bolt	25 – 35	2.5 – 3.5	
14	Master cylinder clamp bolt	5 – 8	0.5 – 0.8	
15	Brake pedal arm bolt	10 – 15	1.0 – 1.5	
16	Swing arm pivot nut	Nut side	54 – 84	5.4 – 8.4
		Bolt side	55 – 85	5.5 – 8.5
17	Rear torque link nut	20 – 30	2.0 – 3.0	
18	Rear shock absorber bolt	Upper and Lower	48 – 72	4.8 – 7.2
19	Rear cushion rod	Upper and Lower	70 – 100	7.0 – 10.0
20	Rear cushion lever nut	70 – 100	7.0 – 10.0	
21	Rear shock absorber bracket nut	70 – 100	7.0 – 10.0	
22	Rear axle nut	50 – 80	5.0 – 8.0	
23	Brake cam lever bolt	5 – 8	0.5 – 0.8	

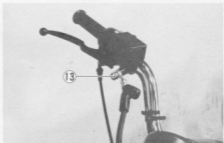
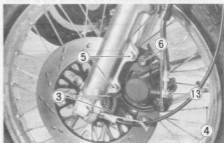

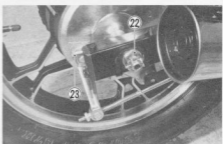
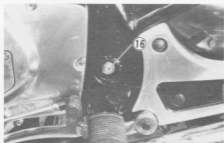
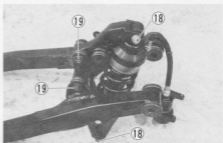
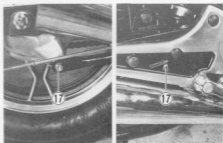
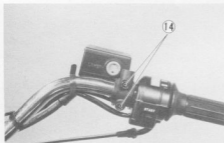

SERVICING ENGINE

CONTENTS

ENGINE COMPONENTS REMOVABLE WITH ENGINE IN PLACE	3- 1
COMPRESSION CHECK	3- 2
ENGINE REMOVAL AND REINSTALLATION	3- 3
ENGINE DISASSEMBLY	3-11
ENGINE COMPONENTS INSPECTION AND SERVICING	3-22
CYLINDER HEAD SERVICING	3-22
VALVE	3-23
VALVE SEAT	3-27
VALVE SPRING	3-29
CAMSHAFT	3-30
CAM CHAIN TENSIONER	3-32
CAM CHAIN	3-33
CYLINDER	3-33
PISTON	3-34
PISTON RING	3-34
CONROD	3-36
CRANKSHAFT	3-37
FLYWHEEL	3-46
OIL PUMP	3-47
CLUTCH	3-48
TRANSMISSION GEAR	3-50
ENGINE REASSEMBLY	3-54

ENGINE COMPONENTS REMOVABLE WITH ENGINE IN PLACE

The parts listed below can be removed and reinstalled without removing the engine from the frame. Refer to the page listed in this section for removal and reinstallation instructions.

ENGINE LEFT SIDE

	See page
Gearshift lever	3-5
Clutch cable	3-5
Engine sprocket cover	3-5
Generator cover	3-16
Generator rotor	3-16
Starter pinion assembly	3-16
Gear position indicator	3-17

ENGINE CENTER

	See page
Air cleaner	2-5
Oil filter	2-12
Fuel tank	3-3
Carburetor and throttle cable	3-5
Exhaust pipe and muffler	3-6
Tachometer cable	3-7
Cam chain tensioner	3-11
Cylinder head breather cover	3-11
Cylinder head cover	3-11
Camshaft	3-11
Cylinder head	3-12
Cylinder	3-12
Piston	3-12
Starter motor	3-16
Oil pan	3-18
Sump filter	3-18

- Starter motor lead wire should be removed from the starter relay side.

ENGINE RIGHT SIDE

	See page
Clutch cover	3-13
Clutch plates	3-14
Clutch sleeve hub	3-14
Primary driven gear	3-14
Oil pump	3-15
Gearshift shaft	3-15
Oil pump drive gear	3-63

COMPRESSION CHECK

The compression of a cylinder is a good indicator of its internal condition. The decision to overhaul the cylinders is often based on the results of a compression test. Periodic maintenance records kept at your dealership should include compression readings for each maintenance service.

Compression pressure

Standard	Limit	Difference
11 – 15 kg/cm ²	9 kg/cm ²	2 kg/cm ²

Low compression pressure can indicate any of the following conditions:

- * Excessively worn cylinder wall
- * Worn-down piston or piston rings
- * Piston rings stuck in the grooves
- * Poor sealing of valves
- * Leaking of otherwise defective cylinder head gasket

Overhaul the engine in the following cases:

- * Compression pressure in one of the cylinders is less than 9 kg/cm².
- * Difference in compression pressure between the two is more than 2 kg/cm².
- * Both compression pressures are below 11 kg/cm² (standard) even when they measure more than 9 kg/cm².

Compression test procedure:

NOTE:

- * Before testing the compression of the engine, make sure that the cylinder head nuts and bolts are tightened to specification.
- * Warm up the engine before testing.

- Remove both spark plugs.
- Fit the compression gauge ① in one of the plug holes, while taking care that the connection is tight.
- Twist the throttle grip full open.
- Crank the engine a few seconds with the starter, and record the maximum gauge reading as the compression of that cylinder.
- Repeat this procedure with the other cylinder.

09915-64510	Compression gauge
09915-63210	Adaptor

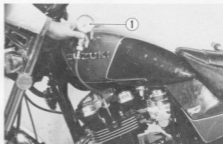

ENGINE REMOVAL AND REINSTALLATION

ENGINE REMOVAL

Before taking the engine out of the frame, wash the engine with a steam cleaner and drain engine oil, etc. The procedure of engine removal is sequentially explained in the following steps, and engine installation is effected by reversing the removal procedure.

1. Place an oil pan under the engine, and remove the oil filter cap and oil drain plug to drain out engine oil.

2. Remove the seat and both frame covers.

3. Set the fuel cock in the "ON" position and shift the fuel hose clip sideways to remove the two hoses (fuel and vacuum) from the fuel cock.

4. Remove the two bolts at the rear of the fuel tank. Disconnect the fuel level gauge lead wire. Remove the tank by moving it rearward.



5. Disconnect various lead wires.

- Battery \ominus and \oplus lead wire ①.
- Signal generator lead ② and oil pressure switch lead ③.
- Generator leads ④.
- Gear position indicator lead ⑤ and neutral indicator lead ⑥.
- Starter relay \ominus lead ⑦.

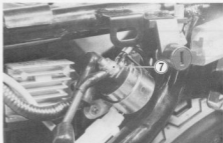
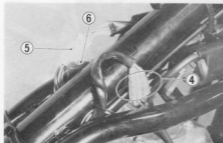
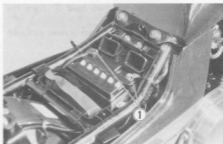

6. Shift the breather pipe clip sideways and remove the pipe from the cylinder head cover cap.



7. Remove the air induction pipe ① from the cylinder head.

Loosen the carburetor clamp screws and take off the carburetor assembly.

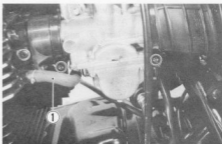

8. Disconnect the throttle cable from throttle valve guide lever and disconnect the choke cable while pushing the lock washer ② to the right.

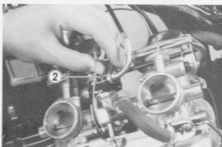

9. Remove the gearshift lever using snap ring pliers.

09900-06107	Snap ring pliers
-------------	------------------



10. Remove the engine sprocket cover using 8-mm box wrench.

09900-00302-015	8-mm box wrench
-----------------	-----------------

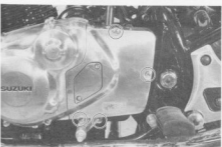

11. Flatten the bent washer on the engine sprocket with a chisel and remove the sprocket. Apply rear brake to remove the mounting nut and sprocket together with the chain from the drive shaft.

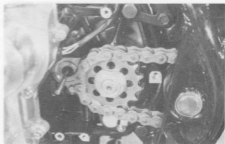

12. Loosen the rear axle nut ① and chain adjuster ②. Push the rear wheel forward and disengage the drive chain from the engine sprocket and rear sprocket.

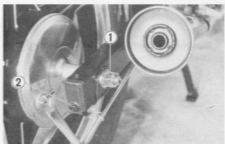

13. Remove the rear brake pedal.



14. Remove the right and left mufflers by unscrewing muffler mounting bolts, exhaust pipe clamp bolts and coupler tube securing bolts.

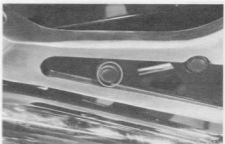

09900-00401

L-type hexagon wrench set



15. Remove the rear shock absorber spring preload adjuster.

16. Remove the spark plug caps and tachometer cable.



17. Remove the engine mounting bolts and brackets.

18. Gradually lift up the engine and lower the engine ass'y on the left side making sure that it does not make contact with the rear bracket. Remove the engine through the left side of the frame.

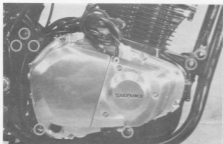

ENGINE REINSTALLATION

Reinstall the engine in the reverse order of engine removal.

- Temporarily fasten the five engine mounting brackets before inserting the engine mounting bolts.
- After inserting the engine mounting bolts tighten engine mounting bracket bolts and engine mounting bolts. Insert all four long bolts from the left side and install the washer on three bolts.

- The engine sprocket should be installed on the drive shaft beforehand, at the same time as installing the drive chain.

If it is difficult to install the engine sprocket, remove the rear axle cotter pin and the axle nut. Remove the wheel assembly and give the drive chain some play. When replacing the engine sprocket nut, stepped side should be faced inside.

- Coat thread lock cement lightly to the inner surface of the engine sprocket spacer.

99000-32040

Thread lock cement

- After inserting the engine mounting bolts, tighten engine mounting bracket bolts and engine mounting bolts.

Tightening torque for engine mounting bolts

	N·m	kg·m
Upper front bolt	67 – 80	6.7 – 8.0
Lower bolt	60 – 72	6.0 – 7.2
Lower rear bolt	60 – 72	6.0 – 7.2
Upper rear bolt	55 – 66	5.5 – 6.6
Mounting bracket bolt	20 – 30	2.0 – 3.0

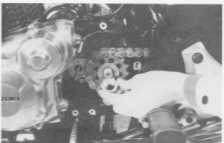
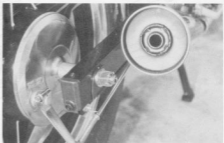

Part	Torque (N·m)	Torque (kg·m)
Engine sprocket nut	60 – 72	6.0 – 7.2
Flange bolt	20 – 30	2.0 – 3.0

- Apply a thin coat of oil to the contact surfaces of the engine sprocket nut and flange bolt. If the contact surfaces are not clean, the engine sprocket nut and flange bolt may not fit properly.

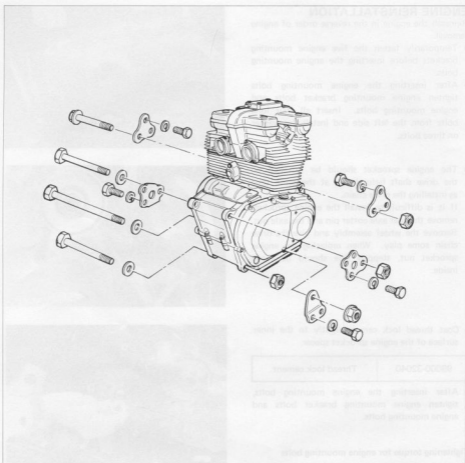

Tightening torque

	N-m	kg-m
Engine sprocket nut	100 – 130	10.0 – 13.0
Rear axle nut	50 – 80	5.0 – 8.0

- Firmly secure the carburetor with the respective clamps. If the carburetor is not firmly secured, gas leakage, incorrect fuel-air ratio and unsatisfactory engine running may result.

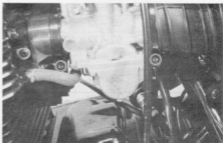

- Before tightening the muffler connector clamp bolt, tighten both left and right muffler mounting bolts and exhaust pipe clamp bolts.

Tightening torque

	N·m	kg·m
Exhaust pipe clamp bolt	20 – 25	2.0 – 2.5
Muffler mounting bolt	40 – 60	4.0 – 6.0
Muffler connector clamp bolt	4 – 7	0.4 – 0.7

- Replace the plug caps on the spark plugs so that their code markings correspond to the cylinders identified "R" or "L".

NOTE:

Two primary terminals on the ignition coil are different in size. As one \oplus is larger than the other one \ominus , connect the lead wires to the proper terminals.

- After remounting the engine, following adjustments are necessary.

	Page
* Throttle cable	2-11
* Choke cable	2-11
* Clutch cable	2-13
* Drive chain	2-13
* Brake light and pedal	2-16

- Route wires and cables correctly.
(See pages 7-16, 7-17, 7-18, 7-19 and 7-20).
- Before starting the engine, make sure that the amount of oil required, according to the type of work done, has been put in.

Engine oil capacity when overhauling engine	3000 ml
---	---------



ENGINE DISASSEMBLY

- Remove cylinder head cover using 6 mm hexagon wrench.

09900-00401

L-type hexagon wrench set

NOTE:

Do not miss the O-rings located with screws.

- While turning the lock screw ① clockwise, remove two mounting bolts ② using 5 mm hexagon wrench.

- Be sure to loosen the four camshaft holder bolts evenly by shifting the wrench diagonally and take off two camshafts.

- Pull out chain guide ③.

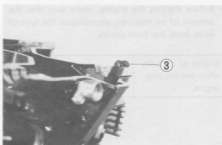
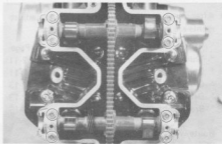
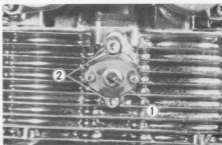
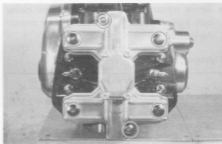

- Remove the 6 mm bolt ① at the front of the chain cavity.

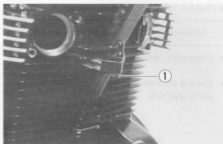
**NOTE:**

When loosening the cylinder head nuts, break each nut loose a little at a time in a descending order according to the numbers cast on a cylinder head.

09914-24510	T handle
09911-74510	Long socket 14 mm

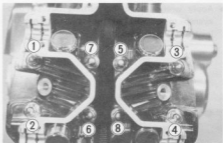

- After removing cylinder head, take a firm grip on the cylinder block at both ends, and lift it straight up. If the block will not come off, lightly tap on the non-fin portions of the block with a plastic mallet to shake the gasketed joint loose.

CAUTION:

Be careful not to damage the fins when removing or handling the cylinder block. This precaution applies to the cylinder head, also.

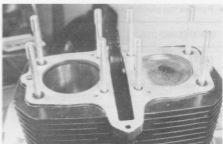

- Put a rag around the connecting rod down in the crankcase to prevent parts from falling into the crankcase. Remove the piston pin circlips and the piston pins.
- Remove both pistons and scribe letters "L" and "R" on the crowns of respective pistons.

09910-34510	Piston pin puller
-------------	-------------------



- Remove the signal generator cover.

09900-06711	7 mm box wrench
-------------	-----------------

- Disconnect the oil pressure switch lead wire ①.
- Remove mounting screws ② for signal generator stator assembly.



- Apply wrench to crank turning nut (14-mm wrench) to remove signal generator rotor mounting bolt (12 mm wrench).

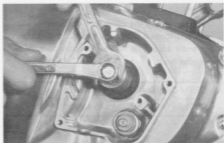

- Remove the clutch cover.

09900-00302-015	8 mm box wrench
-----------------	-----------------

NOTE:

- * One of the bolts **A** holds the gasket.
- * Two of the bolts **B** are tightened with clamps.

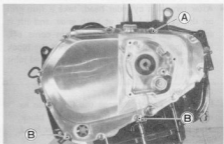

- By holding the crankshaft with conrod holder, remove four clutch spring mounting bolts in a criss-cross manner.

09910-20116	Conrod holder
-------------	---------------

- Remove the clutch springs and pressure plate.

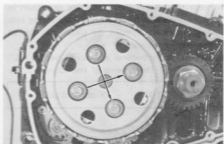

- Remove the clutch push piece ①, thrust bearing ② and thrust washer ③.

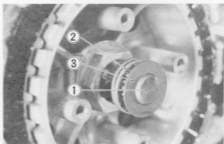

- After removal of clutch drive and driven plates, flatten clutch sleeve hub nut lock washer using chisel.

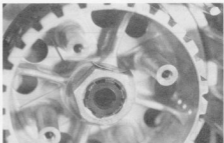

- Firmly secure clutch sleeve hub to remove mounting nut with clutch sleeve hub holder ④.

09920-53721

Clutch sleeve hub holder

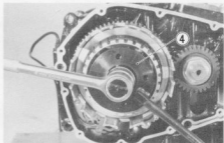
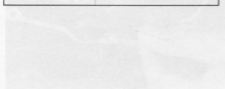

- Remove clutch sleeve hub, thrust washer ⑤ and primary driven gear from the countershaft.

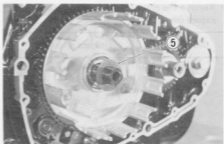

- Pull out primary driven gear spacer ① and thrust washer ②.

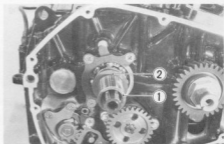

- Using the special tool, remove oil pump driven gear.

09900-06107

Snap ring pliers

- Remove the three oil pump mounting bolts and remove the oil pump body from crankcase.

NOTE:

Do not miss oil pump drive pin, washer and O-ring.

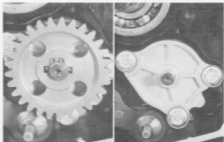

- Draw out gearshift shaft.

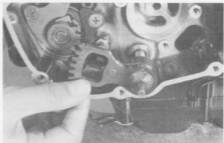

- Remove the countershaft bearing retainer with impact driver.

09900-09003

Impact driver set

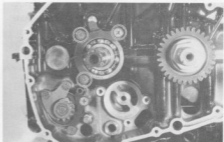
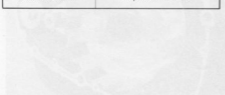

- Remove starter motor cover.
- Remove two bolts, and lightly tap the head of starter motor gear with plastic hammer to remove starter motor.



- Remove generator cover and gasket.

09900-00302-015

8 mm box wrench



- Remove the starter pinion assembly.

NOTE:

A washer is located on each side of the starter pinion assembly.

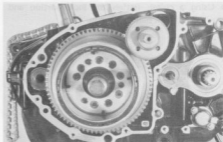

- Using the special tool, remove the rotor securing bolt.

09930-44911

Rotor holder

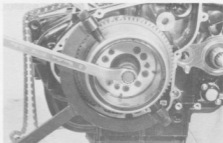

- Install the rotor remover attachment ① and sliding hammer assembly ② into the boss of rotor and remove rotor with flywheel assembly while sliding the remover.

NOTE:

Do not hit the rotor with a hammer.

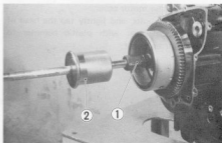

09930-30102	Rotor remover shaft
-------------	---------------------

09930-33710	Attachment
-------------	------------

NOTE:

A piece of magnet is installed at the position

Ⓐ.

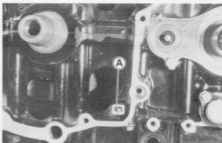

- Using a chisel, flatten the lock portion and remove the oil seal retainer.

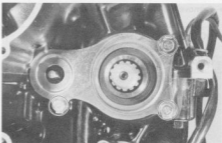

- Remove the gear position indicator switch, O-ring, switch contact and spring.

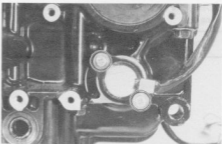

- Remove the upper crankcase tightening bolts.

- Ⓐ : Copper gasket
- Ⓑ : Engine ground lead
- Ⓒ : Gear position indicator lead clamp.

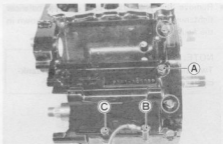

- Turn engine upside down and remove oil pan.

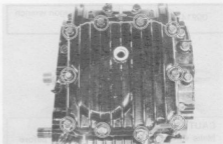

- Remove oil sump filter and oil guide.

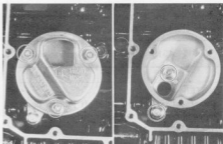

- Remove crankcase tightening bolts. Loosen in a criss-cross manner.

- Ⓓ : Clamp

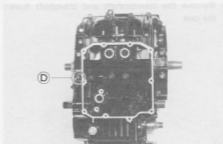

- Remove the crankshaft and counter balancer tightening bolts by descending order as shown in the figure.

NOTE:

Two allen bolts are used for securing crankcase at the portion **A**.

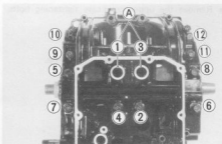

09914-25811

"T" type hexagon wrench
(6-mm)

CAUTION:

Make sure that all bolts are removed before using the crankcase separating tool.

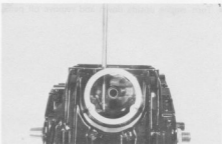

- Using the special tool, separate the upper and lower crankcase halves.

09912-34510

Crankcase separating tool

NOTE:

Beware of dropping crankshaft journal bearings and cam chain tensioner dampers.

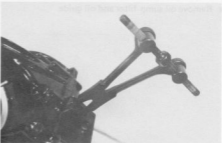

- Remove the countershaft and driveshaft from the case.

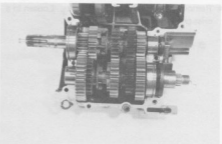

- Remove the crankshaft and counter balancer from the crankcase.

CAUTION:

Remember, the original position of the counter balancer journal bearings and crankshaft journal bearings.

NOTE:

Bear in mind that the crankshaft thrust bearing ① and counter balancer thrust bearing ② are located between the shaft and case.

- Remove the cam chain guide and its two dampers from the upper crankcase.

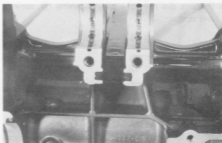
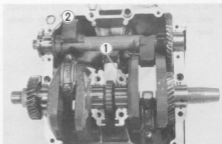

- Using impact driver, remove gearshift cam guide and gearshift pawl screws ③ and ④.

09900-09003

Impact driver set

Overall length of screws

③ : 12 mm

④ : 16 mm

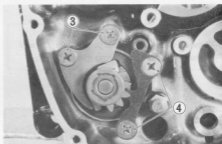

- Unhook the cam stopper spring ⑤ from the lower crankcase.

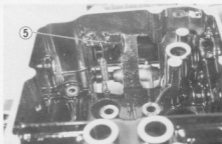

- Hold three gear shifting forks by hand to extract gear shifting fork shaft from the lower crankcase.

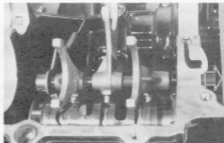

- Remove the neutral stopper housing ①, spring and stopper.

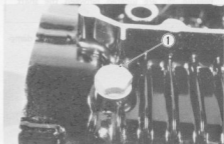

- Extract gearshift cam to the right side.

NOTE:

Remove washer ②, cam driven gear ③ and washer ④ before extracting gearshift cam.

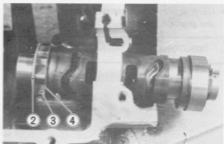
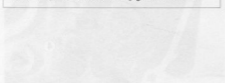

②
③
④

ENGINE COMPONENTS INSPECTION AND SERVICING

CYLINDER HEAD DISASSEMBLY

- Pull out the tappets and shims with fingers.

NOTE:

- * Exercise caution in removing tappets so as not to nick them.
- * Intake tappet is different from exhaust tappet. Make sure to identify exhaust tappet by mark ① on it.

CAUTION:

Be sure to identify each removed part as to its location, and lay the parts out in groups designated as "R", "L", "EXHAUST" and "INLET", so that each will be restored to the original location during reassembly.

- Using the special tools, compress valve springs and take off two cotter halves ② from valve stem.

09916-14510

Valve lifter

09916-84510

Tweezers

- Take out the spring retainer ③, inner and outer springs.



- From the other side, pull out the valve.

NOTE:

Removal of valves completes ordinary disassembling work. If oil seals or valve guides have to be removed for replacement, carry out the following steps.

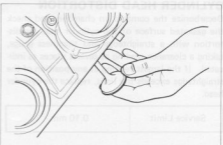
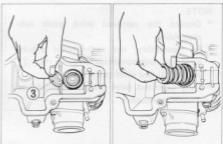
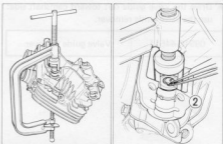
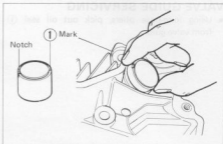

VALVE GUIDE SERVICING

- Using long-nose pliers, pick out oil seal ① from valve guide.



- Drive the valve guide out toward camshaft side; use the valve guide remover.

09916-44511

Valve guide remover

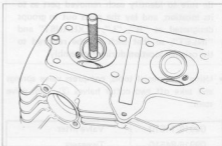
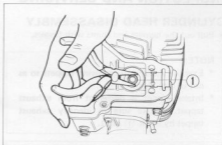

NOTE:

- Discard the removed valve guide sub-assemblies.
- In reassembly, use replacement sub-assemblies, each consisting of guide ring ②, oil seal ③ and valve guide ④.
- Only oversized valve guide are available as a replacement part.

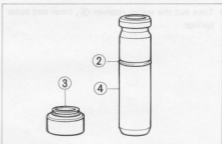

CYLINDER HEAD DISTORTION

Decarbonize the combustion chambers and check the gasketed surface of the cylinder head for distortion with a straightedge and thickness gauge, taking a clearance reading at several places as indicated. If the largest reading at any position of the straightedge exceeds the limit, replace the cylinder head.

Service Limit

0.10 mm

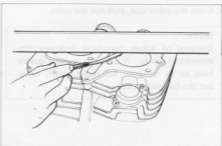

VALVE FACE WEAR

Measure the thickness T and, if the thickness is found to have been reduced to the limit, replace it with a new one.

NOTE:

Visually inspect each valve for wear of its seating face. Replace any valve with an abnormally worn face.

Service Limit	0.5 mm
---------------	--------

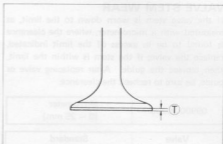

VALVE STEM RUNOUT

Support the valve with "V" blocks, as shown, and check its runout with a dial gauge. The valve must be replaced if the runout exceeds the limit.

09900-21304	V-block (100 mm)
09900-20606	Dial gauge (1/100 mm)

Service Limit	0.05 mm
---------------	---------



VALVE HEAD RADIAL RUNOUT

Place the dial gauge at right angles to the valve head, and measure the valve head radial runout. If it measures more than limit, replace the valve.

Service Limit	0.03 mm
---------------	---------

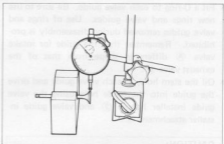

VALVE GUIDE—VALVE STEM CLEARANCE

Measure the clearance in two directions "X" and "Y", perpendicular to each other, by rigging up the dial gauge as shown. If the clearance measured exceeds the limit, specified below, then determine whether the valve or the guide should be replaced to reduce the clearance to the standard range:

Valve	Service Limit
Intake valves	0.35 mm
Exhaust valves	0.35 mm

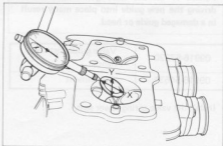

VALVE STEM WEAR

If the valve stem is worn down to the limit, as measured with a micrometer, where the clearance is found to be in excess of the limit indicated, replace the valve; if the stem is within the limit, then replace the guide. After replacing valve or guide, be sure to recheck the clearance.

09900-20205	Micrometer (0 – 25 mm)
-------------	---------------------------

Valve	Standard
Intake valves	6.960 – 6.975 mm
Exhaust valves	6.945 – 6.960 mm

VALVE GUIDE INSTALLATION

- Re-finish the valve guide holes in the cylinder head with a 12.2 mm reamer ① and handle.

09916-34530	12.2 mm reamer
09916-34540	Handle

- Fit a O-ring to each valve guide. Be sure to use new rings and valve guides. Use of rings and valve guides removed during disassembly is prohibited. Remember that the guide for intake valve ① differs in shape from that of the exhaust valve ②.
- Oil the stem hole, in each valve guide and drive the guide into the guide hole using the valve guide installer handle ③ and valve guide installer attachment ④.

CAUTION:

Failure to oil the valve guide hole before driving the new guide into place may result in a damaged guide or head.

09916-57320	Valve guide installer handle
09916-54531	Attachment

- Install the valve spring lower seat.

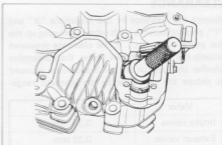
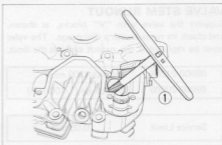
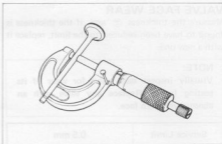

- After fitting all valve guides, re-finish their guiding bores with a 7 mm reamer. Be sure to clean and oil the guides after reaming.

09916-34520	7 mm reamer
09916-34540	Handle

- Oil each oil seal, and drive them into position with the valve stem seal installer. Be sure to use a valve guide installer handle ① and stem seal installer attachment ② on the pushing face of the installer.

NOTE:

Do not use the oil seals removed once: Use new seals.

09916-57320	Valve guide installer handle
09911-94530	Attachment

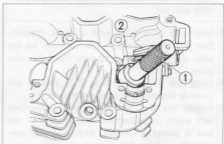
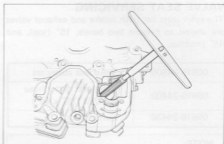
**VALVE SEAT WIDTH**

Coat the valve seat with Prussian blue uniformly. Fit the valve and tap the coated seat with the valve face in a rotating manner, in order to obtain a clear impression of the seating contact. In this operation, use the valve lapper to hold the valve head.

The ring-like dye impression left on the valve face must be continuous—without any break—and, in addition to this requirement, the width of the dye ring, which is the visualized seat “width”, must be within the specification:

Valve seat width

STD: $\text{\textcircled{W}}$	1.0 – 1.2 mm
-------------------------------	--------------

If either requirement is not met, correct the seat by servicing it as follows:

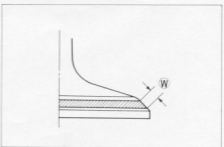
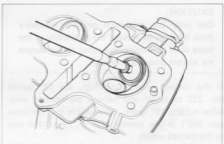

VALVE SEAT SERVICING

The valve seats for both intake and exhaust valves are angled to present two bevels, 15° (top), and 45° (middle).

09916-24900	Valve seat cutter set
09916-24490	Valve seat cutter head No. 233 (15° x 45°)
09916-24430	Cutter blade

NOTE:

The valve seat contact area must be inspected after each cut.

1. Insert the solid pilot with a slight rotation. Seat the pilot snugly. The shoulder on the pilot should be about 10 mm from the valve guide.
2. Using the 45° cutter No. 233, descale and clean up the seat with one or two turns.
3. Inspect the seat by the previously described seat width measurement procedure. If the seat is pitted or burned, additional seat conditioning with the 45° cutter is required.

CAUTION:

Cut only the minimum amount necessary from the seat to prevent the possibility of the valve stem becoming too close to the tappet for correct tappet adjustment.

If the contact area is too high, use 15° cutter No. 233 to lower and narrow the contact area. After cutting 15° angle, it is possible that the valve seat (45°) is too narrow. If so, re-cut the seat to the correct width.

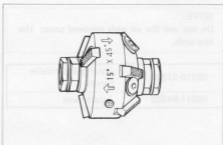
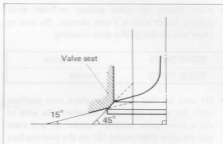

Contact area too high and too wide on face of valve

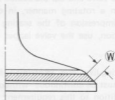

Contact area too low and too narrow on face of valve

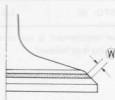

4. After the desired seat position and width is achieved, use the 45° cutter very lightly to clean up any burrs caused by the previous cutting operations. DO NOT use lapping compound after the final cut is made. The finished valve seat should have a velvety smooth finish and not a highly polished or shiny finish. This will provide a soft surface for the final seating of the valve which will occur during the first few seconds of engine operation.
5. Clean and assemble the head and valve components. Fill the intake and exhaust ports with gasoline to check for leaks. If any leaks occur, inspect the valve seat and face for burrs or other things that could prevent the valve from sealing.

NOTE:

- * Always use extreme caution when handling gasoline.
- * After servicing the valve seats, be sure to adjust the tappet clearance after the cylinder head has been reinstalled.

6. If, by any chance, too much stock has been removed from the seat during the refacing work resulting in loss of the specified shim disc clearance even with the thinnest shim disc, then the only remedy is to grind off the stem end face of the valve with a valve refacer, thereby shortening the overall length of the valve.

CAUTION:

- * This remedy is permissible where the length ① will not be reduced to less than 4.0 mm. If this length becomes shorter than 4.0 mm, then the valve must be replaced.
- * After installing the valve whose stem end has been ground off as above, check that the face ② of valve stem end is above the cotter ③.

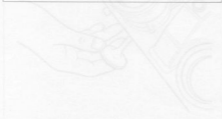
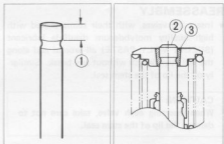
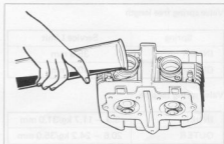
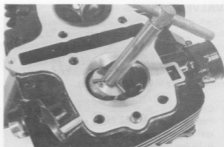

VALVE SPRINGS

Check the springs for strength by measuring their free lengths and also the force required to compress them. If the limit indicated below is exceeded by the free length reading or if the measured force does not fall within the range specified, replace with a new SUZUKI spring.

CAUTION:

Replace both of the inner and outer valve springs at a time, if any one of these is found to be less than the limit.

Valve spring free length

Spring	Service Limit
INNER	35.9 mm
OUTER	40.1 mm

Valve spring tension

INNER	9.9 – 11.7 kg/31.0 mm
OUTER	20.6 – 24.2 kg/35.0 mm

REASSEMBLY

- Insert the valves, with their stems coated with high quality molybdenum disulfide lubricant (SUZUKI MOLY PASTE) all around and along the full stem length without any break. Similarly oil the lip of the stem seal.

CAUTION:

When inserting each valve, take care not to damage the lip of the stem seal.

99000-25140

SUZUKI moly paste

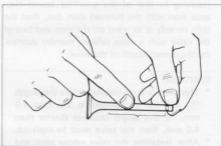
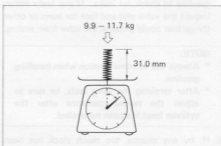
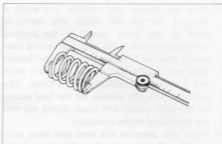

- Install the valve springs with the small pitch portion **A** facing cylinder head.
B : Large pitch portion.

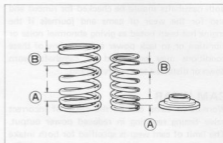

- Put on the valve retainer and, using the valve lifter, press down the springs, fit the two cotter halves to the stem end, and release the lifter to allow the cotter **1** to wedge in between seat and stem. Be sure that the rounded lip **2** of the cotter fits snugly into the groove **3** in the stem end.

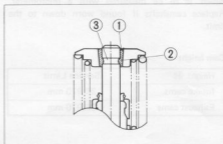

- Oil each valve tappet and the bore in which it slides. Push the tappet into the bore with your fingertips. Only a light force is required to push it in.

CAUTION:

- * Be sure to restore each spring, tappet and shim to their original positions.
- * Exhaust tappet has a mark **A** on the top and is different from intake tappet.

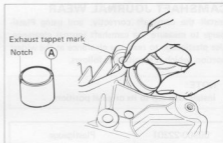

CAMSHAFT

The exhaust camshaft can be distinguished from that of the intake by the embossed letters "EX" (for exhaust) as against letters "IN" (for intake). Similarly, the right end can be distinguished "R" from the left end "L" of each camshaft.

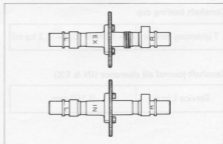

Both camshafts should be checked for runout and also for the wear of cams and journals if the engine has been noted as giving abnormal noise or vibration or to lack power output. Any of these conditions may be caused by camshafts worn down or distorted to the service limit.

CAM WEAR

Worn-down cams can be the cause of incorrect valve timing resulting in reduced power output. The limit of cam wear is specified for both intake and exhaust cams in terms of cam height H , which is to be measured with a micrometer. Replace camshafts if found worn down to the limit.

Cam height

Height H	Service Limit
Intake cams	36.970 mm
Exhaust cams	36.970 mm

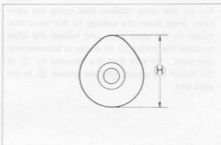
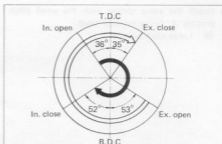

CAMSHAFT JOURNAL WEAR

Install the camshaft correctly, and using Plastigauge to measure the camshaft journal clearance. Use plastigauge to read the clearance at the widest portion, which is specified as follows.

NOTE:

Install each cap to its original position.

09900-22301	Plastigauge
-------------	-------------

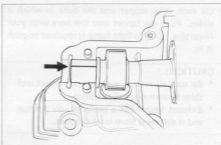

Camshaft bearing cap

Tightening torque	8 – 12 N·m (0.8 – 1.2 kg·m)
-------------------	-----------------------------

Camshaft-journal oil clearance (IN & EX)

Service Limit	0.150 mm
---------------	----------



If the camshaft journal clearance measured exceeds the limit, measure the inside diameter of camshaft bearing cap and outside diameter of camshaft. Replace either the cylinder head or the camshaft, whichever the difference from specification is greater.

Item	Standard
Camshaft journal holder I.D. (IN & EX)	22.012 – 22.025 mm
Camshaft journal O.D. (IN & EX)	21.959 – 21.980 mm

CAM SPROCKET REASSEMBLY

- It is very important that each sprocket be positioned angularly on its camshaft as illustrated. Its correct position is determined by arrow mark "3" (on INTAKE sprocket) or arrow marks "1" and "2" (on EXHAUST sprocket) located (as shown) in reference to the notch ① in the camshaft right end.
- Apply **THREAD LOCK CEMENT SUPER "1303B"** to the threads of bolts, and tighten them to the following specification.
- Bend the lock washer positively.

Tightening torque	17 – 19 N·m (1.7 – 1.9 kg·m)
-------------------	---------------------------------

99000-32030	Thread lock "1303B"
-------------	---------------------

CAM CHAIN TENSIONER

INSPECTION

- Turn the cylinder shaft ① with a screw driver in the clockwise direction, and move the push rod ② in place to see if it slides smoothly. If any stickiness is noted, replace the chain tensioner assembly with a new one.

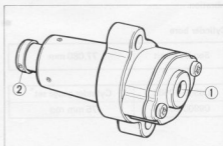
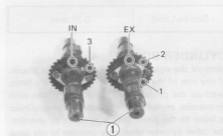
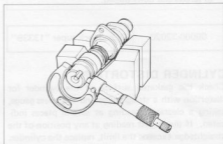
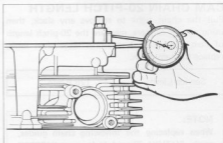

CAM CHAIN 20-PITCH LENGTH

Pull the chain tight to remove any slack, then using vernier calipers, measure the 20-pitch length of cam chain. If it measures more than limit, replace the cam chain.

Service Limit	128.9 mm
---------------	----------

NOTE:

When replacing the following chain guides, apply SUZUKI Thread lock super "1333B" to screws and bolts thread.

99000-32020	Thread lock super "1333B"
-------------	---------------------------

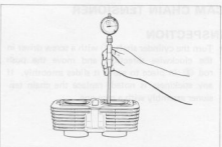
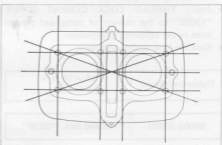
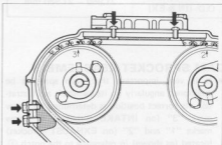
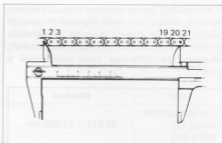
**CYLINDER DISTORTION**

Check the gasketed surface of the cylinder for distortion with a straightedge and thickness gauge, taking a clearance reading at several places indicated. If the largest reading at any position of the straightedge exceeds the limit, replace the cylinder.

Cylinder distortion specification

Service Limit	0.10 mm
---------------	---------

CYLINDER BORE

Measure the cylinder bore diameter at six places. If any one of the measurements exceeds the limit, overhaul the cylinder and replace the piston with an oversize, or replace the cylinder. If one cylinder is worn to the point that it needs to go oversize, the other cylinder should go oversize at the same time. Otherwise the imbalance might cause excess vibration.

Cylinder bore

Service Limit	77.080 mm
---------------	-----------

09900-20508	Cylinder gauge set
09900-20509	75 mm rod

PISTON DIAMETER

Using a micrometer, measure the piston outside diameter at the place shown in Fig. If the measurement is less than the limit, replace the piston.

Piston oversize	0.5, 1.0 mm
-----------------	-------------

Service Limit	76.880 mm
---------------	-----------

09900-20204	Micrometer (75-100 mm)
-------------	------------------------

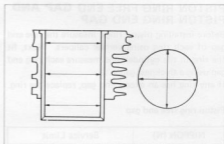

PISTON-CYLINDER CLEARANCE

As a result of the above measurement, if the piston clearance exceeds the limit shown in the table below, rebore the cylinder and use an oversize piston, or replace both cylinder and piston.

Service Limit	0.120 mm
---------------	----------

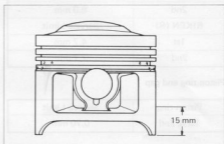

PISTON RING-GROOVE CLEARANCE

Using a thickness gauge, measure the side clearances of the 1st and 2nd rings. If either of the clearances exceeds the limit, replace both piston and piston rings.

09900-20803	Thickness gauge
-------------	-----------------

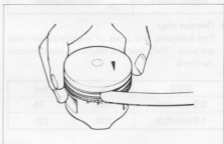

Piston ring-groove clearance

Piston ring	Service Limit
1st	0.18 mm
2nd	0.15 mm

Piston ring thickness

Piston ring	Standard
1st	0.970 – 0.990 mm
2nd	1.170 – 1.190 mm

Piston ring groove width

Piston ring	Standard
1st	1.01 – 1.03 mm
2nd	1.21 – 1.23 mm
Oil	2.51 – 2.53 mm

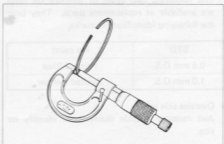

PISTON RING FREE END GAP AND PISTON RING END GAP

Before installing piston rings, measure the free end gap of each ring using vernier calipers. Next, fit the ring in the cylinder, and measure each ring end gap using a thickness gauge.

If any ring has an excess end gap, replace the ring.

Piston ring free end gap

NIPPON (N)	Service Limit
1st	5.6 mm
2nd	8.0 mm
RIKEN (R)	Service Limit
1st	4.7 mm
2nd	7.7 mm

Piston ring end gap

Piston ring	Service Limit
1st & 2nd	0.70 mm

09900-20803	Thickness gauge
-------------	-----------------

• Oversize rings

The following two types of oversize piston rings are used. They bear the following identification numbers.

SIZE	1st	2nd
0.5 mm O.S.	50	50
1.0 mm O.S.	100	100

• Oversize oil rings

The following two types of oversize oil rings are available as replacement parts. They bear the following identification marks.

STD	No paint
0.5 mm O.S.	Painted Blue
1.0 mm O.S.	Painted Yellow

• Oversize side rail

Just measure outside diameter to identify its size.

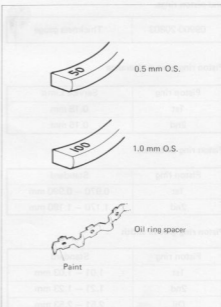
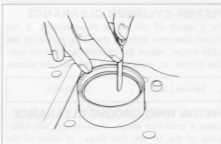
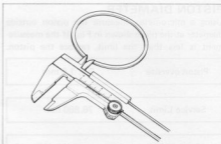

PISTON PIN—PIN BORE CLEARANCE

Using a caliper gauge, measure the piston pin bore inside diameter, and using a micrometer, measure the piston pin outside diameter. If the difference between these two measurements is more than the piston pin-to-pin bore clearance limit, replace both piston and piston pin.

Piston pin bore I.D.

Service Limit	18.030 mm
---------------	-----------

Using a micrometer, measure the piston pin outside diameter at three positions.

Piston pin O.D.

Service Limit	17.980 mm
---------------	-----------

09900-20605	Dial caliper
09900-20205	Micrometer (0–25 mm)

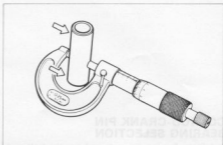
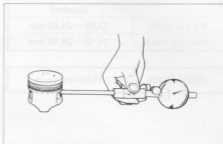

CONROD SMALL END BORE I.D.

Using a caliper gauge, measure the conrod small end diameter.

Conrod small end bore I.D.

Service Limit	18.040 mm
---------------	-----------

- If the difference between the conrod small end bore inside diameter and the piston pin outside diameter exceeds the abovementioned limit, replace both conrod and piston pin.

CONROD BIG END THRUST CLEARANCE

Check the conrod thrust clearance by using thickness gauge. If the clearance exceeds the limit, replace conrod or crankshaft.

Service Limit	0.30 mm
---------------	---------

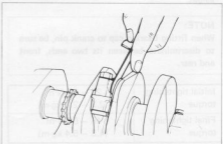
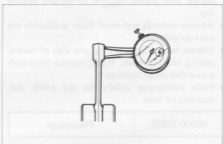

Checking conrod big end thrust clearance.

	Standard
Big end width	23.95 – 24.00 mm
Crank pin width	24.10 – 24.15 mm

09900-20803	Thickness gauge
-------------	-----------------

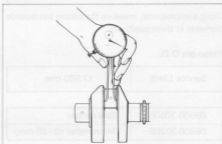
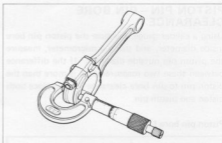

CONROD-CRANK PIN BEARING SELECTION

- Loosen bearing cap nuts and tap the bolt end lightly with plastic hammer to remove bearing cap.
- Remove conrods and mark them to identify the cylinder position.
- Inspect bearing surfaces for any sign of fusion, pitting, burn or flaws. If any, replace them with a specified set of bearings.
- Place plastigauge axially on the crank pin, avoiding oil hole.

09900-22301	Plastigauge
-------------	-------------

- Tighten the bearing cap with two-step torque values.

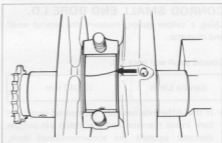

NOTE:

When fitting bearing cap to crank pin, be sure to discriminate between its two ends, front and rear.

Initial tightening torque	22 – 28 N·m (2.2 – 2.8 kg·m)
Final tightening torque	48 – 54 N·m (4.8 – 5.4 kg·m)

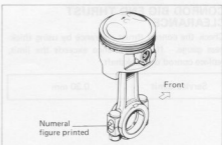

NOTE:

Never rotate crankshaft or conrod when a piece of Plastigauge is in the clearance.

- Remove the caps and measure the width of compressed plastigauge with envelope scale. This measurement should be taken at the widest part.

Service Limit	0.080 mm
---------------	----------

- If oil clearance has exceeded service limit, select the specified bearings from the following table.
- Check the corresponding rod I.D. code number ①, "1" or "2".
- Check the corresponding crank pin O.D. code number, "1", "2" or "3".
- The crank pin O.D. code number ② is on the inside of left crank web.

Bearing selection table

	Code	Crank pin O.D. code		
		1	2	3
Conrod I.D. code	1	Green	Black	Brown
	2	Black	Brown	Yellow

Oil clearance

Standard	0.024 – 0.048 mm
----------	------------------

Conrod I.D. specification

Code	Conrod I.D.
1	39.000 – 39.008 mm
2	39.008 – 39.016 mm

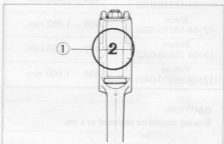
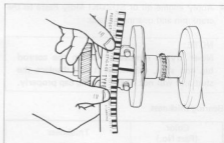

Crank pin O.D. specification

Code	Crank pin O.D.
1	35.992 – 36.000 mm
2	35.984 – 35.992 mm
3	35.976 – 35.984 mm

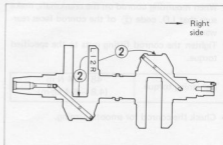

- Apply engine oil or SUZUKI Moly Paste to the crank pin and bearing surface.

NOTE:

Never try to remove or loosen the conrod big end stud, otherwise, it will displace the stud and will not fit the bearing cap properly.

Bearing thickness

Color (Part No.)	Thickness
Green (12164-15510-010)	1.484 – 1.488 mm
Black (12164-15510-020)	1.488 – 1.492 mm
Brown (12164-15510-030)	1.492 – 1.496 mm
Yellow (12164-15510-040)	1.496 – 1.500 mm

CAUTION:

Bearing should be replaced as a set.

BEARING ASSEMBLY

- When fitting the bearings to the bearing cap and conrod, be sure to fix the stopper part ① first and press the other end.

NOTE:

Coat all crankshaft bearings with SUZUKI Moly paste before reassembly.

- When mounting conrod on the crankshaft, make sure that I.D. code ② of the conrod faces rearward.
- Tighten the conrod fitting nuts to the specified torque.

Tightening torque	48 – 54 N·m (4.8 – 5.4 kg·m)
-------------------	---------------------------------

- Check the conrod for smooth turning.

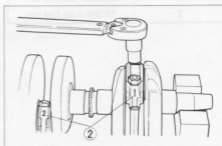
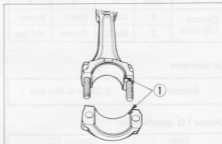
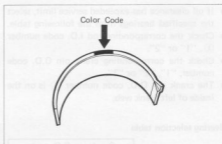
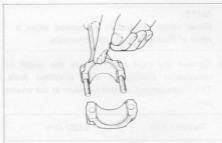

CRANKCASE-CRANKSHAFT AND COUNTER BALANCER BEARING SELECTION

- Inspect each bearing-of upper and lower crankcases for any damage.
- Place plastigauge on each crankshaft and counter balancer journal in the usual manner.

NOTE:

Do not place the plastigauge on the oil hole, and do not rotate the shafts when plastigauge is in place.

- Mate the lower crankcase with the upper crankcase and tighten the crankcase securing bolts with specified torque value in the following order.

Item	Initial	Final
① - ⑧	13 N·m (1.3 kg·m)	20 - 24 N·m (2.0 - 2.4 kg·m)
⑨ - ⑫	6 N·m (0.6 kg·m)	9 - 13 N·m (0.9 - 1.3 kg·m)

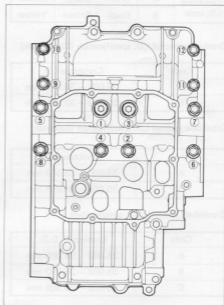
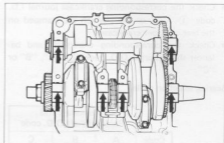

- Remove the lower crankcase and measure the width of compressed plastigauge in the usual manner.

Service Limit	0.080 mm
---------------	----------

- If the width exceeds the limit, replace the set of bearings with new ones by referring to the selection table.

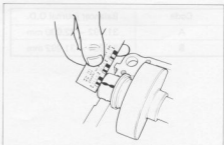

- Check the corresponding crankcase journal I.D. code ①, "A" or "B", which are stamped on the rear of upper crankcase.
- Check the corresponding crankshaft and balancer shaft journal O.D. code ②, "A", "B" or "C".

Bearing selection table

Crankcase I.D. code	Code	Crankshaft and Balancershaft O.D. code		
		A	B	C
	A	Green	Black	Brown
	B	Black	Brown	Yellow

Crankcase journal I.D. specification (Crankshaft)

Code	Crankcase I.D.
A	39.000 – 39.008 mm
B	39.008 – 39.016 mm

Crankcase journal I.D. specification (Balancer)

Code	Crankcase I.D.
A	35.000 – 35.008 mm
B	35.008 – 35.016 mm

Crankshaft journal O.D. specification

Code	Crankshaft O.D.
A	35.992 – 36.000 mm
B	35.984 – 35.992 mm
C	35.976 – 35.984 mm

Counter balancer journal O.D. specification

Code	Balancer journal O.D.
A	31.992 – 32.000 mm
B	31.984 – 31.992 mm

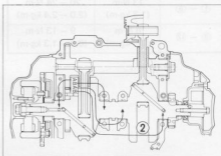
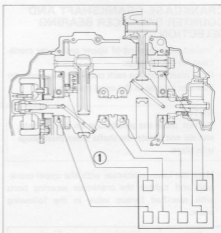

Bearing thickness specification (Crankshaft journal bearing)

Color (Part number)	Specification
Green (12229-15510-010)	1.486 – 1.490 mm
Black (12229-15510-020)	1.490 – 1.494 mm
Brown (12229-15510-030)	1.494 – 1.498 mm
Yellow (12229-15510-040)	1.498 – 1.502 mm

Bearing thickness specification (Balancer journal bearing)

Color (Part number)	Specification
Green (12229-11400-010)	1.486 – 1.490 mm
Black (12229-11400-020)	1.490 – 1.494 mm
Brown (12229-11400-030)	1.494 – 1.498 mm
Yellow (12229-11400-040)	1.498 – 1.502 mm

CRANKSHAFT THRUST CLEARANCE

- Check the crankshaft thrust clearance with thickness gauge.

Standard clearance	0.08 – 0.12 mm
--------------------	----------------

- Check the crankshaft thrust bearing thickness for wear. If most wearing portion exceeds the following limit, replace it with a new one.

Service Limit	2.70 mm
---------------	---------

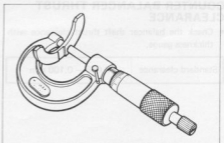
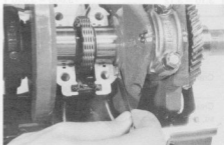
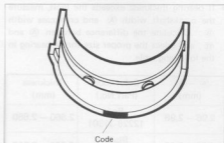

- If bearing thickness exceeds the limit, measure the crankshaft width (A) and crankcase width (B). Calculate the difference between (A) and (B), and select the proper size thrust bearing in the following table.

(A) - (B) (mm)	Color code (Part No.)	Thickness (mm)
2.96 - 2.98	Red 12228-31301	2.860 - 2.880
2.98 - 3.00	Black 12228-31302	2.880 - 2.900
3.00 - 3.02	Blue 12228-31303	2.900 - 2.920
3.02 - 3.04	Green 12228-31304	2.920 - 2.940
3.04 - 3.06	Yellow 12228-31305	2.940 - 2.960
3.06 - 3.08	White 12228-31306	2.960 - 2.980
3.08 - 3.10	Brown 12228-31307	2.980 - 3.000
3.10 - 3.12	Pink 12228-31308	3.000 - 3.020

EXAMPLE:

Crankshaft width (A) is: 58.06 mm

Crankcase width (B) is: - 54.98 mm

Clearance (A) - (B) is: 3.08 mm
so, select the Brown color bearing.

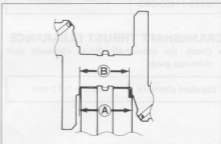
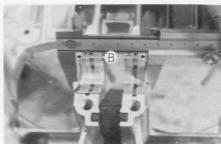
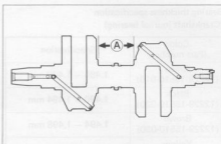
**COUNTER BALANCER THRUST CLEARANCE**

- Check the balancer shaft thrust clearance with thickness gauge.

Standard clearance	0.045 - 0.100 mm
--------------------	------------------

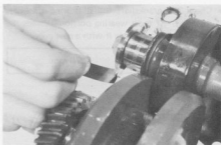

- Check the counter balancer thrust bearing thickness for wear. If most wearing portion exceeds the following limit, replace it with a new one.

Service Limit	2.75 mm
---------------	---------

- If bearing thickness exceeds the limit, measure the balancer journal width (A) and crankcase journal holder width (B). Calculate the difference between (A) and (B), and select the proper size thrust bearing in the following table.

(A) - (B) (mm)	Color code (Part No.)	Thickness (mm)
2.970 - 2.995	Green 12228-44104	2.900 - 2.925
2.995 - 3.020	Black 12228-44105	2.925 - 2.950
3.020 - 3.045	NIL 12228-44106	2.950 - 2.975
3.045 - 3.070	Brown 12228-44107	2.975 - 3.000
3.070 - 3.100	Yellow 12228-44108	3.000 - 3.025

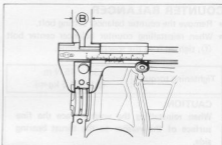
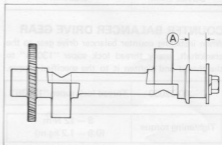
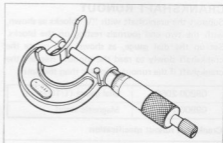

EXAMPLE:

Counter balancer journal width (A) is:
20.01 mm

Crankcase width (B) is:
17.00 mm

Clearance (A) - (B) is 3.01 mm
so, select the Black color bearing.

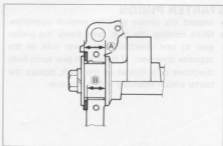

CRANKSHAFT RUNOUT

Support the crankshaft with "V" blocks as shown, with the two end journals resting on the blocks. Set up the dial gauge, as shown, and rotate the crankshaft slowly to read the runout. Replace the crankshaft if the runout is greater than the limit.

09900-20606	Dial gauge (1/100 mm)
09900-20701	Magnetic stand

Crankshaft runout specification

Service Limit	0.05 mm
---------------	---------

COUNTER BALANCER DRIVE GEAR

When installing counter balancer drive gear to the crankshaft, apply thread lock super "1303B" to the thread and tighten it to the specified torque.

99000-32030	Thread lock super "1303B"
-------------	---------------------------

Tightening torque	8 – 12 N·m (0.8 – 1.2 kg·m)
-------------------	--------------------------------

COUNTER BALANCER

- Remove the counter balancer setting bolt.
- When reinstalling counter balancer center bolt ①, tighten it to the specified torque.

Tightening torque	35 – 45 N·m (3.5 – 4.5 kg·m)
-------------------	---------------------------------

CAUTION:

When reinstalling the washer, face the fine surface of the washer to the thrust bearing side.

STARTER PINION

- Inspect the pinion gear for smooth operation.
- While holding idle gear, turn freely the pinion gear to one direction and never turn to the opposite direction. If the pinion gear turns both directions or is locked on the shaft, replace the starter pinion assembly with a new one.

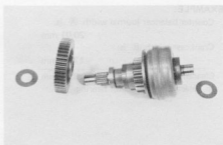
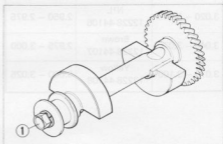
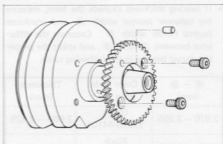
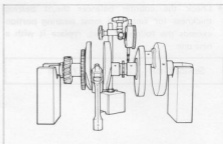

FLYWHEEL ASSEMBLY

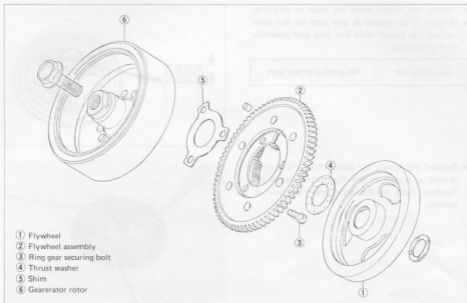

REASSEMBLY

- Install the shim ① to the proper position.
- Apply thread lock to allen bolts and tighten to the specified torque.

99000-32030

Thread lock super "1303B"

09914-25811

T-type hexagon wrench
(6 mm)

Tightening torque

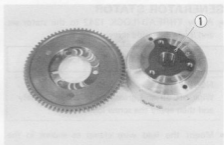
15 – 20 N·m
(1.5 – 2.0 kg·m)

- Inspect the clutch shoe for wear or chipping.
- If there is no groove at any part on the shoe, replace the clutch shoe and ring gear assembly with a new one.

Service Limit	No groove at any part
---------------	-----------------------

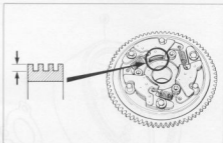

- Expand the spring by using three plain screw drivers as shown in the figure and install the flywheel mass to the shoe and ring gear assembly.



GENERATOR STATOR

- Apply **THREAD LOCK 1342** to the stator set and lead wire guide screws.

99000-32050	Thread lock "1342"
-------------	--------------------

NOTE:

Wipe off oil and grease on screw completely and then apply the screw lock.

- Mount the lead wire clamp as shown in the photo.

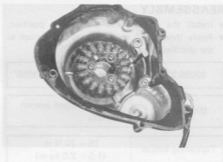

OIL PUMP

WARNING:

Oil pump case securing screw is applied with **SUZUKI THREAD LOCK SUPER "1303B"**. Do not attempt to overhaul the oil pump assembly. The oil pump unit is available as an assembly only.



CLUTCH DRIVE PLATES AND DRIVEN PLATES

Clutch plates in service remain in oily condition as if they were lubricated with oil. Because of this condition, both drive and driven plates are subject to little wearing action and therefore last much longer. Their life depends largely on the quality of oil used in the clutch and also on the way the clutch is operated.

These plates are expendable: they are meant to be replaced when found worn down or distorted to the respective limit: use a caliper to check thickness and a thickness gauge and surface plate to check distortion.

09900-20102	Vernier calipers
09900-20803	Thickness gauge

Unit: mm

Service Limit	Drive plate		Driven plate
	No. 1	No. 2	
Thickness	2.6	3.2	—
Distortion	—	—	0.1
Claw width	15.1	15.1	—

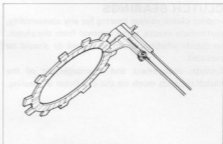

Checking thickness

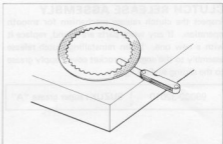

Checking distortion

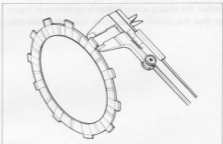

Checking claw width

CLUTCH SPRING FREE LENGTH

Measure the free length of each coil spring with vernier calipers, and compare the elastic strength of each with the specified limit. Replace all the springs if any spring is not within the limit.

Clutch spring free length

Service Limit	34,0 mm
---------------	---------

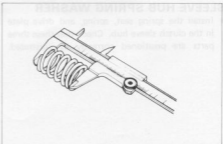

CLUTCH BEARINGS

Inspect clutch release bearing for any abnormality, particularly cracks, upon removal from the clutch, to decide whether it can be reused or should be replaced.

Smooth engagement and disengagement of the clutch depends much on the condition of bearing.

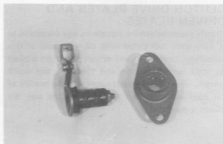

CLUTCH RELEASE ASSEMBLY

Inspect the clutch release mechanism for smooth operation. If any worn parts are found, replace it with a new one. When reinstalling clutch release assembly to the engine sprocket cover, apply grease to the sliding surface lightly.



99000-32010

SUZUKI super grease "A"

Install the sliding screw properly as shown in figure so that the clutch release lever operates positively.

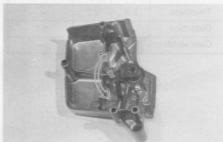

SLEEVE HUB SPRING WASHER

- Install the spring seat, spring, and drive plate in the clutch sleeve hub. Check that these three parts are positioned correctly as illustrated.

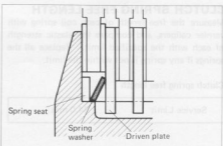

TRANSMISSION

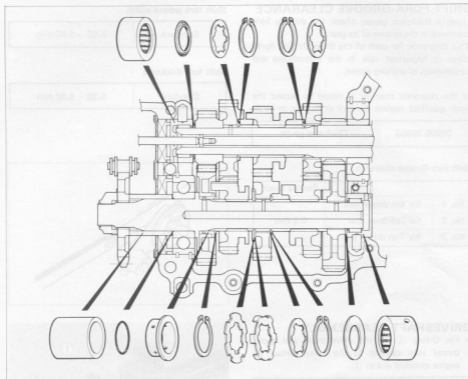

MOUNTING 2ND DRIVE GEAR

Force-fit 2nd drive gear to a position where the distance between this drive gear and the 1st drive gear assumes the value indicated:

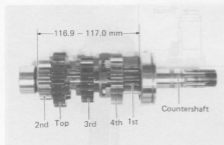

Countershaft length (low to 2nd)

STD Length	116.9 – 117.0 mm
99000-32030	Thread lock super "1303B"

NOTE:

- Before mounting 2nd drive gear, apply **THREAD LOCK SUPER "1303B"** to its bore, taking care not to smear Top drive gear with "SUPER 1303B".
- After mounting the 2nd drive gear, check that top drive gear spins smoothly by moving it with your fingers.

SHIFT FORK-GROOVE CLEARANCE

Using a thickness gauge, check the shifting fork clearance in the groove of its gear.

This clearance for each of the three shifting forks plays as important role in the smoothness and positiveness of shifting action.

If the clearance checked is noted to exceed the limit specified, replace the fork or its gear, or both.

09900-20803	Thickness gauge
-------------	-----------------

Shift fork-Groove clearance

		Service Limit
No. 1	for 4th driven gear	0.5 mm
No. 2	for 3rd drive gear	
No. 3	for Top driven gear	

Shift fork groove width

Standard	5.50 – 5.60 mm
----------	----------------

Shift fork thickness

Standard	5.30 – 5.40 mm
----------	----------------

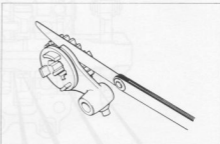
**DRIVESHAFT REASSEMBLY**

- Fix O-ring (1) to the drive shaft and apply thread lock cement to the inner surface of engine sprocket spacer (2).

99000-32040	Thread lock cement
-------------	--------------------

- Coat SUZUKI super grease "A" to the lip of oil seal.

99000-25010	SUZUKI super grease "A"
-------------	-------------------------

- When mounting circlip, pay attention to the direction of the circlip. Fit it to the side where the thrust is as shown in the figure with the rounded side against the gear surface.

CAUTION:
Always use new circlip when reassembling.

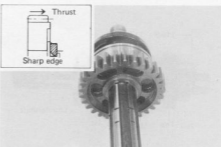
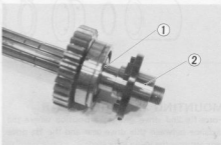

* After mounting the circlip, be sure to check the thrust side with your finger.

CAUTION:

Never reuse a circlip after a circlip has been removed from a shaft, it should be discarded and a new circlip must be installed.

When installing a new circlip, care must be taken not to expand the end gap larger than required to slip the circlip over the shaft. After installing a circlip, always insure that it is completely seated in its groove and securely fitted.

- Install the Top driven gear on the drive shaft.
- Insert the lock washer ① into the drive shaft, and turn it to fit it into the groove. Then fit the lock washer ② in the lock washer ①.



- Install 3rd driven gear ③, washer ④ and circlip ⑤ on the drive shaft.

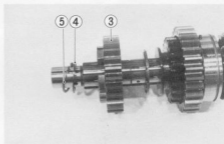

- Install the 4th and low driven gears.

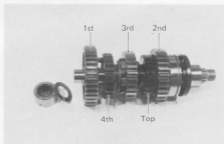

COUNTERSHAFT OIL SEAL

- Inspect countershaft oil seal (1) for any damage. If any damage is noted, replace it with a new one.

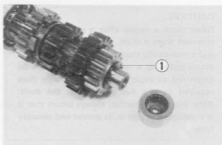

Inspect the oil seal (1) for any damage. If any damage is noted, replace it with a new one.

Inspect the oil seal (1) for any damage. If any damage is noted, replace it with a new one.

Inspect the oil seal (1) for any damage. If any damage is noted, replace it with a new one.

ENGINE REASSEMBLY

The engine is reassembled by carrying out the steps of disassembly in the reversed order, but there are a number of steps which demand special descriptions or precautionary measures.

NOTE:

Apply engine oil to each running and sliding part before reinstalling.

- The shape of each gearshifting pawl is different. Mount the one with the narrow width on the gearshifting cam guide.

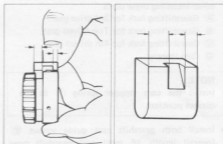

- Mount the gearshift pawl ① on the gearshifting cam as shown.
- Mount the cam driven gear ④ on the gearshifting cam.

- ① Pawl
② Push piece
③ Spring

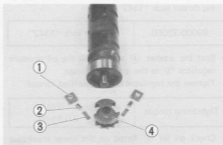

- Install the gearshift cam to the lower crankcase and install washer ⑤, gearshift cam stopper ⑥ on the positioning pin ⑦ and washer ⑧.

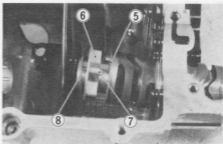

- Install the gearshifting cam with the dent for the neutral stopper directed downward, and meet the neutral stopper ① with this dent ②.
- Tighten the neutral stopper housing to the following torque value.

Tightening torque	18 – 28 N·m (1.8 – 2.8 kg·m)
-------------------	---------------------------------

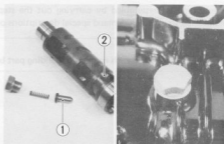

- Refer to the following figure in regard to the correct positions and orientations of the forks when installing these parts.

- Ⓐ Gearshifting fork for 3rd drive gear.
- Ⓑ Gearshifting fork for Top driven gear.
- Ⓒ Gearshifting fork for 4th driven gear.
- Ⓓ Cam stopper.

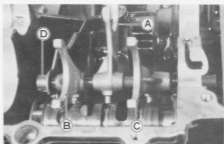
**NOTE:**

Install the cam stopper spring ③ in the correct position.

- Install both gearshift cam guide screws ⑤ (overall length 16 mm) and gearshift pawl screws ⑥ (overall length 12 mm) with applying thread lock "1342".

99000-32050	Thread lock "1342"
-------------	--------------------

- Seat the washer ④ and install the oil pressure regulator ⑤ to the lower crankcase. Tighten the regulator to the specified torque.

Tightening torque	17 – 20 N·m (1.7 – 2.0 kg·m)
-------------------	---------------------------------

- Check oil jet ⑥ fitted on the lower crankcase for clogging.

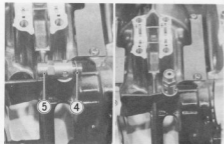
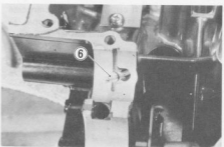
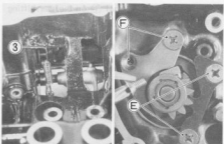

- Before installing the bearings to the upper crankcase, check the two oil jets ① for clogging.

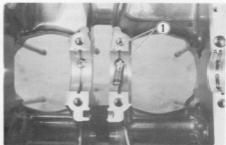

- When fitting the bearings to the crankcase, be sure to fix the stopper part ② first and press the other end.

CAUTION:

Do not touch the bearing surfaces with your hands. Grasp by the edge of the bearing shell.



- Apply SUZUKI Moly Paste to each journal bearing lightly.

99000-25140

SUZUKI moly paste

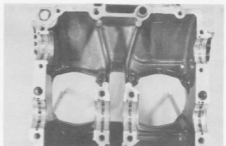

- Place cam chain guide ③ properly, and fix two dampers ④ so that iron side faces to the chain guide pin (inside).

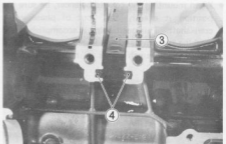
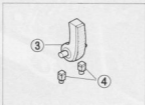

- Install the crankshaft thrust bearing ① and counter balancer thrust bearing ② to the position shown in the figure.
- Thrust bearings ① and ② go into place with their oil groove side facing outside.

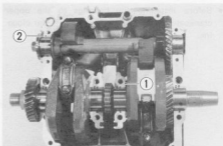

- The washer between primary drive gear and nut is in dish form when it is in free state. When fitting this washer, be sure to face its concave side to the gear as shown.

Tightening torque	90 – 110 N·m (9.0 – 11.0 kg·m)
-------------------	-----------------------------------

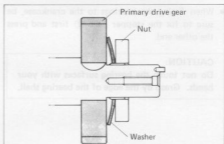

- Mount the crankshaft with cam drive chain in the upper crankcase.

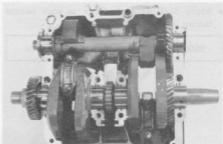

- When mounting the counterbalancer, be sure to position it exactly 180° out of phase with crankshaft. This positioning is accomplished by meshing the drive and driven gears in such a way that the two punch marks ③ meet each other, as shown.



- Install the two C-ring to the positions, ① and ②, as shown.
- Check the bearing positioning pins ③.



- Be sure to install the bearing dowel pins ④ in the locations indicated.
- Make sure that the countershaft turns freely while holding the drive shaft. If not, shift the gear which is engaged to the neutral position.
- Clean the mating surfaces of the crankcases before matching the upper and lower ones.
- Apply SUZUKI BOND NO. 1207B to the mating surface of the lower crankcase in the following procedure.

99000-31140

SUZUKI Bond No. 1207B

NOTE:

Use of SUZUKI BOND NO. 1207B is as follows:

- * Make surface free from moisture, oil, dust and other foreign materials.
- * Spread on surfaces thinly to form an even layer and assemble the cases within few minutes.
- * Take extreme care not to apply any bond No. 1207B to the bearing surfaces.
- * Applicable on distorted surface as it forms a comparatively thick film.

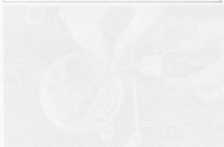
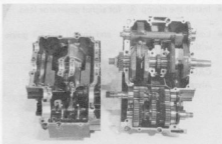
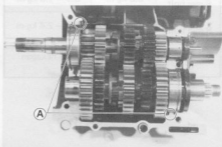
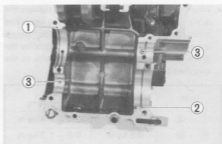

- When securing the lower crankcase, tighten the 8-mm bolts and the 6-mm bolts in the ascending order of numbers assigned to these bolts, tightening each bolt a little at a time to equalize the pressure. Tighten all the securing bolts to the specified torque values.

Item	Initial tightening	Final tightening
① - ⑧	1.3 kg-m	2.0 - 2.4 kg-m
⑨ - ⑫	0.6 kg-m	0.9 - 1.3 kg-m
The other 6 mm bolt	0.6 kg-m	0.9 - 1.3 kg-m
The other 8 mm bolt	1.3 kg-m	2.0 - 2.4 kg-m

09914-25811

6 mm T-type hexagon wrench

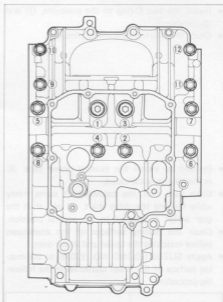

- Install the clamp (A) for signal generator lead.
- Locate the O-ring (B) and install the oil guide with two bolts.

CAUTION:

Always use new O-ring.

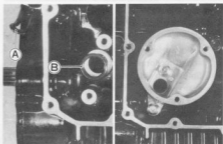

- Install the oil sump filter to face the oil inlet to the front.
- Apply thread lock "1342" to the three bolts.

99000-32050

Thread lock "1342"



- Install the new gasket and tighten oil pan bolts to the specified torque.

Tightening torque	8 – 12 N·m (0.8 – 1.2 kg-m)
-------------------	--------------------------------

- Install the signal generator lead clamp (A).

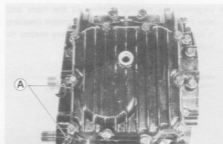

- Tighten the upper crankcase bolts to the specified torque values.

Tightening torque	N·m	kg-m
6 mm bolt	9 – 13	0.9 – 1.3
8 mm bolt	20 – 24	2.0 – 2.4

- ① Copper gasket
- ② Engine ground lead
- ③ Gear position indicator lead clamp

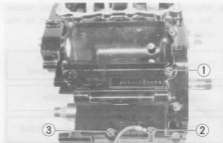

- Install the gear position indicator switch.

NOTE:

When installing the gear position indicator switch, be sure to locate spring, switch contact (4) and new O-ring (5).

- Tighten oil seal guide plate bolts and bend the lock portion of the plate.

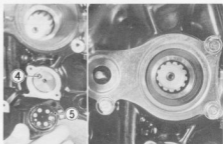

- Thick copper washer is mounted with the chamfered side (B) facing in.

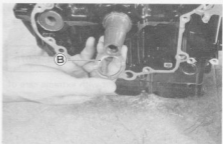

- Degrease the tapered portion of the rotor and also the crankshaft. Use non-flammable cleaning solvent to wipe off the oily or greasy matter to make these surfaces completely dry.

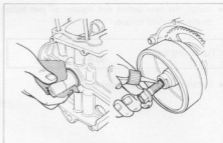

- After mounting the rotor and flywheel, secure the rotor by tightening the center bolt to the specified torque value.

Tightening torque	150 – 170 N·m (15.0 – 17.0 kg·m)
09930-44911	Rotor holder
99000-32100	Thread lock super "1305"

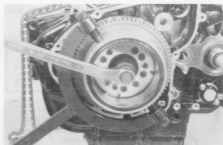

- Install the starter pinion assembly and its shaft.

NOTE:

A thrust washer ① is located on each side of the starter pinion as shown in the figure.

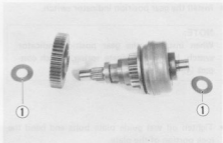

- Coat SUZUKI Bond No. 1207B lightly to the portion around mating surface between crank-cases as shown.

99000-31140	SUZUKI Bond No. 1207B
-------------	-----------------------

- Fit generator cover gasket with extreme care of oil passage ②.
- Install the magnet to the position ③.

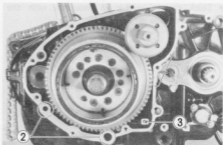

- Install the generator cover to the crankcase.

NOTE:

- * Always use new gasket, and install two positioning pins.
- * Route generator lead wire and gear position indicator lead wire properly.

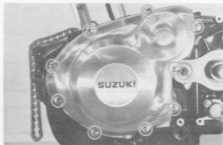

- Mount the starter motor and route the lead wire properly.

99000-32050

Thread lock "1342"

- Fit the starter motor cover.



- Install the countershaft bearing retainer screws.

99000-32050

Thread lock "1342"

Overall screw length: 16 mm

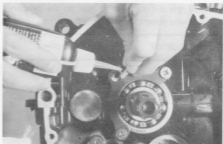

- Install the gearshift shaft, with the center of the gear on shaft side aligned the center of gearshift cam driven gear.



- Be careful not to leave out the "O" ring ① when fitting oil pump.
- Apply thread lock "1342" to oil pump fitting bolts.

Tightening torque	7 – 9 N·m (0.7 – 0.9 kg·m)
-------------------	-------------------------------

99000-32050	Thread lock "1342"
-------------	--------------------

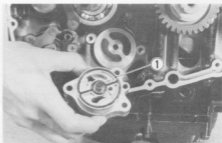

- Position washer and oil pump drive pin ② and fix the oil pump driven gear with circlip ③.

NOTE:

Upon installing the oil pump in crankcase, rotate the pump gear by hand to see if it turns smoothly.

09900-06107	Snap ring pliers
-------------	------------------

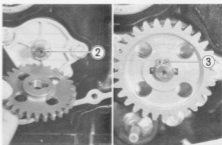

- Install the oil pump drive gear to the primary driven gear assembly with snap ring pliers.

09900-06107	Snap ring pliers
-------------	------------------



- Install washer ④ and primary driven gear spacer ⑤ on the countershaft.

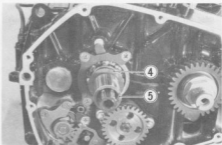

- Install the primary driven gear and thrust washer ①.

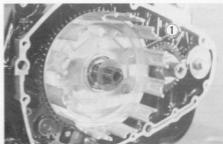

- Install the clutch plate damper ② and its seat ③ on the clutch sleeve hub.



- After tightening the clutch sleeve hub nut ④, be sure to lock the nut by positively bending the tongue of the washer. Tightening torque for the nut is specified.

09920-53721

Clutch sleeve hub holder

Tightening torque

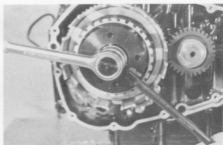
40 – 60 N·m
(4.0 – 6.0 kg·m)

- Thicker driven plate (cork plate) is the first to go into the sleeve hub.
- Install push rod, push piece ⑤, thrust bearing ⑥ and thrust washer ⑦ properly.

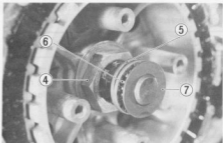

NOTE:

Using conrod holder, tighten the clutch spring set bolts in the indicated manner, making sure that they are tightened just a little at a time to the same final tightness.

09910-20116

Conrod holder

Tightening torque

8 – 12 N·m
(0.8 – 1.2 kg·m)

- Coat SUZUKI Bond No. 1207B lightly to the portion around mating surface between crankcases as shown.

99000-31140

SUZUKI Bond No. 1207B

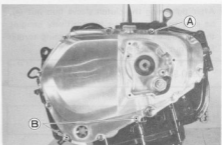
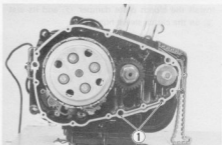
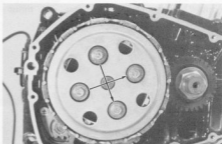

- Replace a new clutch cover gasket and two positioning pins.
- Fit clutch cover gasket with extreme care of oil passage ①.
- Coat grease to the oil seal lip.
- Install the clutch cover to the crankcase.

Ⓐ : Gasket

Ⓑ : Clamp

- Apply SUZUKI Bond No. 1207B to oil pressure switch thread.

99000-31140

SUZUKI Bond No. 1207B

- Install the signal generator rotor after installing the clutch cover. Be sure to position the rotor in place so that its groove ② will admit locating pin ③ provided on crankshaft.

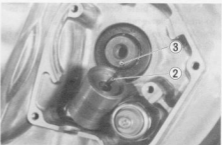

- Use the 14-mm wrench ① to hold crankshaft steady when tightening signal generator rotor bolt.

Tightening torque	18 – 28 N·m (1.8 – 2.8 kg·m)
-------------------	---------------------------------

- Tighten the signal generator stator with two screws and connect oil pressure switch lead ② properly.
- Route the signal generator lead wire as shown.

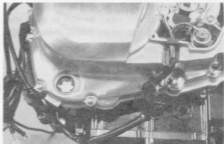
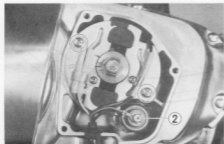
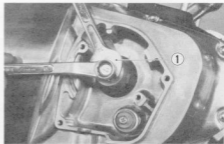

- Check the two oil jet ③ for clogging.
- The piston is in correct position when its arrow (on the crown) points forward.
- Be sure to install the piston in the cylinder from which it was taken out in disassembly, refer to the letter mark, "R" or "L", scribed on the piston crown.
- Have each piston oiled lightly before installing it.
- Place a rag beneath the piston, and install the circlip.
- Be sure to use new circlips.

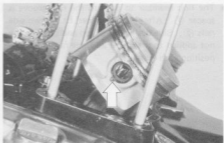
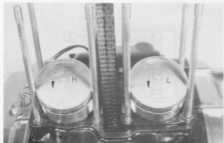

- Top ring and middle (2nd) ring differ in the shape of ring face. The face of top ring is chrome-plated whereas that of 2nd ring is not. The color of 2nd ring appears darker than that of the top one.

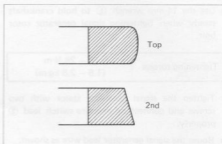

- Top and middle (2nd) rings have letter "N" or "R" marked on the side. Be sure to bring the marked side to top when fitting them to the piston.

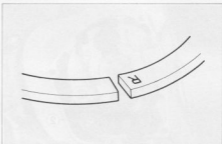

- The spacer of bottom ring (oil ring) is either of "N" type or of "R" type. Be sure that the three rings (top, 2nd and oil) for a piston are all "N" rings or "R" rings: use of one or two "N" rings and two or one "R" rings on a piston is not permitted.

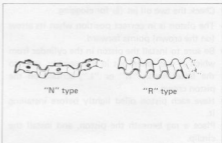

- The first member to go into the ring groove is spacer ①. After placing spacer, fit the two side rails ②. Side designations, top and bottom, are not applied to the spacer and side rails: you can position each either way.

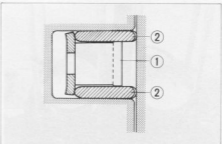

CAUTION:

If the spacer is of "N" type, be careful not to allow its two ends to overlap in the groove.



- Position the gaps of the three rings as shown. Before inserting each piston into the cylinder, check that the gaps are so located.



- Before putting on the cylinder block, oil the big and small ends of each conrod and also the sliding surface of each piston.
- Install piston ring holders in the indicated manner. Some light resistance must be overcome to lower the cylinder block.

09916-74520	Holder body
09916-74540	Band (bore 63 – 75 mm)

NOTE:

- Do not overtighten the special tool bands or pistons will not slide into the cylinders.
- Each band has a number punchmarked on it. The number refers to a particular range of piston diameter.

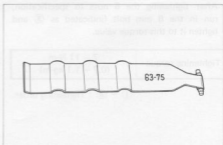
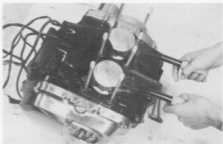
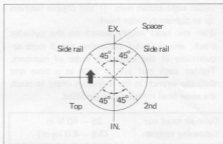
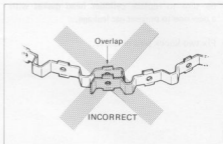

- Be sure to replace cylinder head gasket with a new one to prevent gas leakage.
- Fix two knock pins properly.



- Install eight crown nuts ① and copper washers ② to tighten cylinder head.
- With the head snugly seated on the cylinder block, secure it by tightening the 8 nuts sequentially in the ascending order of numbers. Tighten each nut just a little at a time and shift the wrench in the indicated order to reach the same final torque value specified.

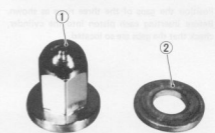

Cylinder head nut tightening torque	35 – 40 N·m (3.5 – 4.0 kg·m)
--	---------------------------------

- After tightening the 8 nuts to specification, run in the 6 mm bolt (indicated as ③) and tighten it to this torque value.

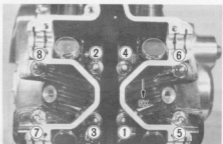

Tightening torque	7 – 11 N·m (0.7 – 1.1 kg·m)
-------------------	--------------------------------

① ~ ⑧ : Tightening order.

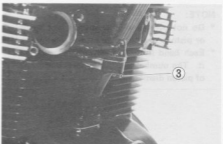

- Place chain guide ① properly.

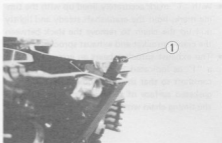

- While holding the timing chain, rotate the crankshaft in normal direction to bring the "T" mark to the timing mark.

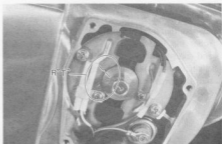

CAUTION:

To turn over crankshaft, torque nut ② with a 14 mm wrench. Never try to rotate crankshaft by putting a 12 mm wrench to bolt ③.

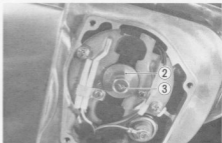

NOTE:

Just before placing the camshaft on the cylinder head, apply high quality molybdenum disulfide lubricant to its journals, fully coating each journal ④ with the paste taking care not to leave any dry spot. Apply engine oil to the journal bearings.

99000-25140

SUZUKI moly paste

- Identify exhaust camshaft from intake one by the cast-out letters "EX" (for exhaust) as against letters "IN" (for intake). Also tell the right end "R" from the left end "L" of each camshaft.



- With "T" mark accurately lined up with the timing mark, hold the crankshaft steady and lightly pull up the chain to remove the slack between the crank sprocket and exhaust sprocket.
- The exhaust sprocket bears an arrow mark and a "1" as indicated ①. Turn over the exhaust camshaft so that the arrow points flush with the gasketed surface of the cylinder head. Engage the timing chain with this sprocket.

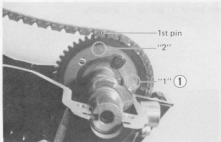

- The other arrow mark "2" is now pointing straight upward. Count the chain roller pins toward the intake camshaft, starting from the roller pin directly above this arrow mark "2" and ending with the 24th roller pin. Engage the chain with intake sprocket, locating the 24th pin, the arrow mark "3" on the intake sprocket.



NOTE
 After the timing chain is installed, turn the crankshaft clockwise until the timing mark on the crankshaft is aligned with the timing mark on the cylinder head. Turn the crankshaft clockwise until the timing mark on the cylinder head is aligned with the timing mark on the crankshaft.

NOTE
 After the timing chain is installed, turn the crankshaft clockwise until the timing mark on the crankshaft is aligned with the timing mark on the cylinder head. Turn the crankshaft clockwise until the timing mark on the cylinder head is aligned with the timing mark on the crankshaft.

NOTE
 After the timing chain is installed, turn the crankshaft clockwise until the timing mark on the crankshaft is aligned with the timing mark on the cylinder head. Turn the crankshaft clockwise until the timing mark on the cylinder head is aligned with the timing mark on the crankshaft.

NOTE:

The timing chain is now riding on all three sprockets. Be careful not to disturb the crankshaft until four holders are secured.

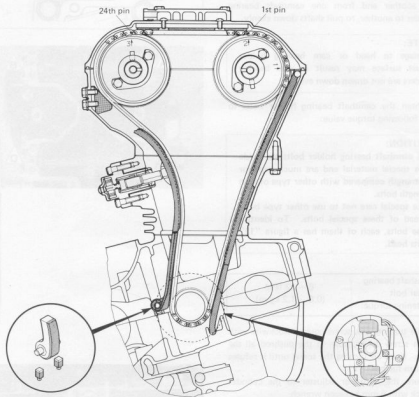

- Each camshaft holder is identified with a cast-on letter with a triangle. A matching cast-on symbol appears on the head. Install each holder at its matching letter, with triangle symbols pointing forward.
- Secure the four camshaft bearing holders evenly by tightening the camshaft bearing holder bolts sequentially. Try to equalize the pressure by moving the wrench diagonally from one bolt to another and from one camshaft bearing holder to another, to pull shafts down evenly.

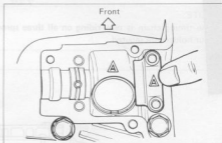
**NOTE:**

Damage to head or cam bearing holder thrust surface may result in cam bearing holders are not drawn down evenly.

- Tighten the camshaft bearing holder bolts to the following torque value:

CAUTION:

The camshaft bearing holder bolts are made of a special material and are much superior in strength compared with other type of high strength bolts.

Take special care not to use other type bolts instead of these special bolts. To identify these bolts, each of them has a figure "11" on its head.

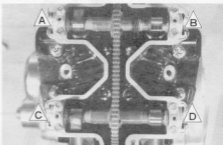

Camshaft bearing holder bolt	8 – 12 N·m (0.8 – 1.2 kg·m)
tightening torque:	

- While turning lock screw counterclockwise with plain screw driver, push in the pushrod all the way. Keep on turning the screw until it refuses to turn further.
- Secure the tensioner adjuster to the cylinder block with 5 mm hexagon wrench.

Tightening torque	6 – 8 N·m (0.6 – 0.8 kg·m)
-------------------	-------------------------------

- Remove the screw driver from the lock screw and check that the cam drive chain is stretched without play.

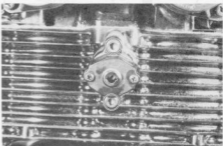

- Adjust tappet clearance.
(Refer to page 2-6).
- In fitting the seal ring to the oil filter chamber cap, lightly coat grease on the seal ring ① groove to avoid any chance of dropping or mislocating the ring during the installation work.

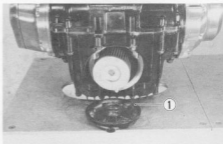

- Tighten engine oil drain plug.

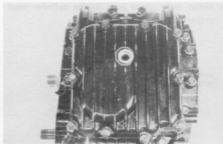

- Pour 50 ml of engine oil into the four oil pockets in the head.

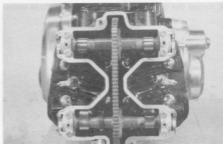

- Install cylinder head cover and cover cap.
When reinstalling the cylinder head cover, apply SUZUKI Bond No. 1207B to the mating surface between oil seal and head cover and four camshaft end seals.

99000-31140

SUZUKI Bond No. 1207B

Cylinder head
cover tightening
torque13 – 15 N.m
(1.3 – 1.5 kg-m)

- Install new O-ring ① to the intake pipe groove as shown.

CAUTION:

Always use new O-ring to prevent sucking air from the joint part.

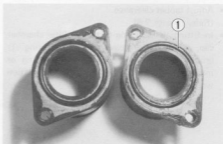

- Install each intake pipe to the cylinder head properly.



- Install the signal generator cover with three bolts.

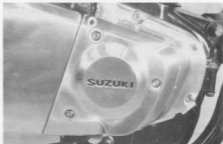

Install cylinder head cover and cover cap.
After installing the cylinder head cover, apply
SUZUKI Bond No. 1307B to the contact surface
between oil seal and head cover and fasten
head and seal.

SUZUKI Bond No. 1307B	85000-31180
1.3 - 1.8 mm (0.051 - 0.071 in.)	Cylinder head cover gasket torque

FUEL AND LUBRICATION SYSTEM

CONTENTS

FUEL SYSTEM	4- 1
FUEL COCK	4- 2
CARBURETOR	4- 3
DIAPHRAGM AND PISTON OPERATION	4- 5
SLOW SYSTEM	4- 6
MAIN SYSTEM	4- 7
STARTER SYSTEM	4- 8
FLOAT SYSTEM	4- 8
FUEL LEVEL INSPECTION	4- 9
DISASSEMBLY	4-10
FLOAT HEIGHT ADJUSTMENT	4-13
NEEDLE VALVE	4-13
REASSEMBLY	4-14
BALANCING CARBURETORS	4-16
LUBRICATION SYSTEM	4-18
OIL PRESSURE	4-18
LUBRICATION SYSTEM CHART	4-19
OIL JET PISTON COOLING	4-21



FUEL SYSTEM

When engaging starter motor, negative pressure is generated in the combustion chamber. This negative pressure works on the diaphragm of fuel cock through passageway provided in the carburetor main bore and vacuum pipe, and diaphragm builds up a negative pressure which is higher than the spring pressure. Fuel valve is forced to open due to diaphragm operation, and thus allow fuel to flow into carburetor float chamber.

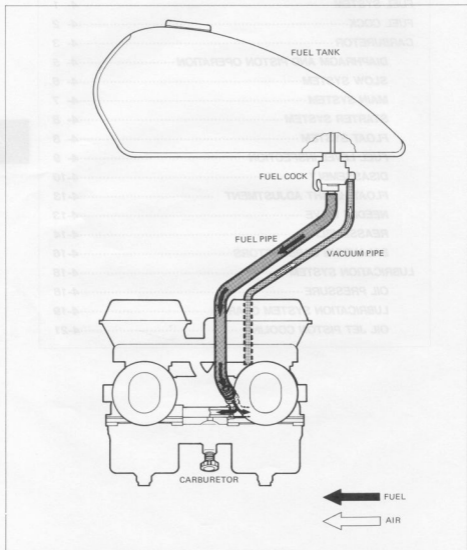

FUEL COCK

CARBURATORE

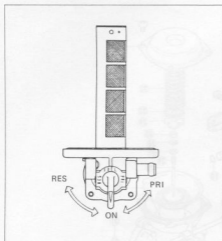

When the engine is not running and the valve in the ON or RES position, the fuel valve is kept in the closed position by applying pressure utilizing a spring so that no fuel will flow to the carburetors. When the engine is engaged, a negative pressure is generated in the diaphragm chamber "C" through the vacuum (negative pressure) pipe which is connected to the right carburetor, and builds up a negative pressure which is higher than the spring pressure so that the diaphragm is forced to open the fuel valve and thus allow the fuel to flow to the carburetors.

When the lever is set to PRI position, the protrusion ⑥ located on the lever end pushes back the fuel valve mechanically against the spring force and it allows fuel to flow to the carburetors directly, whether the engine is running or not, through the RES side fuel filter and fuel valve clearance.

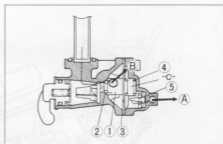

"ON"

- | | | |
|--------------|-----------------|-------------|
| ① Fuel valve | ② O-ring | ③ Diaphragm |
| ④ Spring | ⑤ One-way valve | ⑥ Cam |
| Ⓐ Vacuum | Ⓑ Fuel flow | |

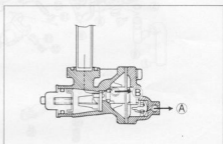

"RES"

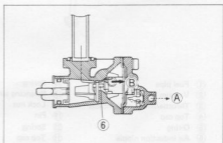

"PRI"

CARBURETOR

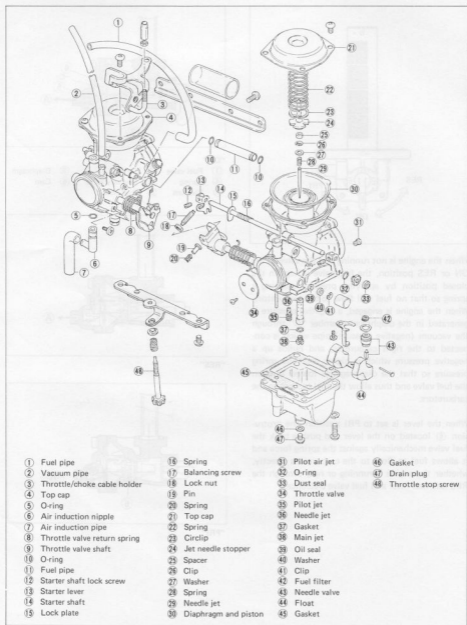

SPECIFICATIONS

ITEM	SPECIFICATIONS
Type	MIKUNI BS36SS
I.D. No.	15500
Bore	36 mm
Idle r/min	1300 ± 50 r/min
Fuel level	5.0 ± 0.5 mm
Float height	23.0 ± 1.0 mm
Main jet	# 130
Main air jet	0.6 mm
Jet needle	5CO8-3rd
Needle jet	Y-8
Pilot jet	# 42.5
By pass	0.9, 0.9, 1.3 mm
Pilot air jet	# 130
Pilot outlet	1.3 mm
Valve seat	2.0
Throttle valve	# 90
Starter jet	# 30
Pilot screw	Pre-set
Throttle cable play	0.5 – 1.0 mm
Chock cable play	0.5 – 1.0 mm

I.D. NO. LOCATION

Each carburetor has I.D. Number ① printed on the carburetor body according to its specifications.



DIAPHRAGM AND PISTON OPERATION

The carburetor is of a variable-venturi type, whose venturi cross section area is increased or decreased automatically by the piston according to the vacuum present on the downstream side of the venturi. Vacuum is admitted into the diaphragm chamber through an orifice provided in the piston.

Rising vacuum overcomes the spring force, causing the piston to rise to increase the said area and thus to prevent the air velocity from increasing. Therefore, air velocity in the venturi passage is kept relatively constant for improved fuel atomization and for securing an optimum ratio of fuel to air in the mixture.

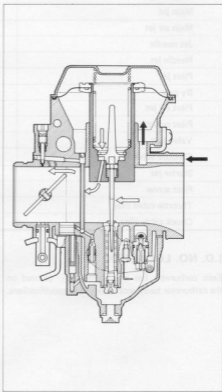
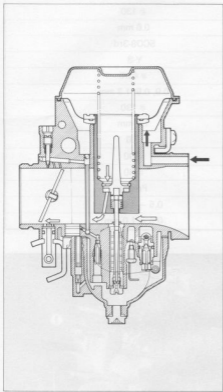

SLOW SYSTEM

This system supplies fuel during engine operation with throttle valve closed or slight opened. The fuel from float chamber is metered by pilot jet where it mixes with air coming in through pilot air jet. This mixture, rich with fuel, then goes up through pilot pipe to pilot screw. A part of the mixture is discharged into the main bore out of bypass ports. The remainder is then metered by pilot screw and sprayed out into the main bore through pilot outlet.

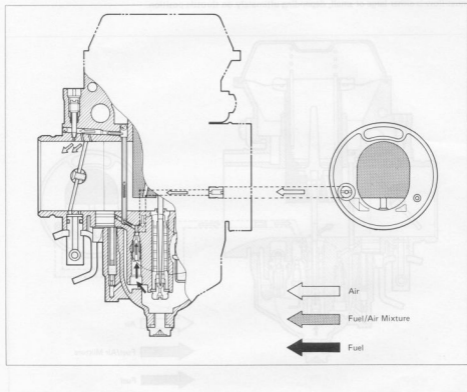

MAIN SYSTEM

As the throttle valve is opened, engine speed rises, and this increases vacuum in the venturi. Consequently the piston valve moves upward.

Meanwhile, the fuel in float chamber is metered by main jet, and the metered fuel enters needle jet, in which it mixes with the air admitted through main air jet to form an emulsion.

The emulsified fuel then passes through the clearance between needle jet and jet needle, and is discharged into the venturi, in which it meets main air stream being drawn by the engine.

Mixture proportioning is accomplished in the needle jet; the clearance through which the emulsified fuel must flow is either large or small, depending ultimately on throttle position.

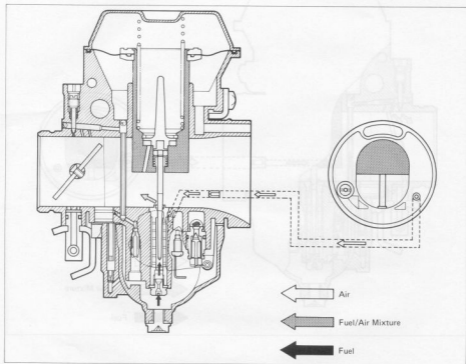

STARTER SYSTEM

Turning the choke lever allows the starting plunger to draw fuel into the starter circuit from the float chamber through starter jet.

Starter jet meters this fuel, which then flows into starter pipe and mixes with the air coming from the float chamber. The mixture, rich in fuel content, reaches starting plunger and mixes again with the air coming through a passage extended from behind the diaphragm.

The two successive mixings of fuel with air are such that proper air/fuel mixture for starting is produced when the mixture is sprayed out through starter outlet into the main bore.

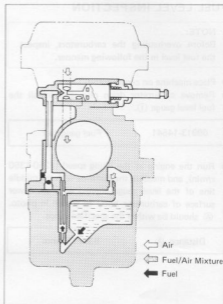

FLOAT SYSTEM

Floats and needle valve are associated with the same mechanism, so that, as the floats move up and down, the needle valve too moves likewise. When fuel level is up in float chamber, floats are up and needle valve remains pushed up against valve seat. Under this condition, no fuel enters the float chamber.

As the fuel level falls, floats go down and needle valve unseats itself to admit fuel into the chamber. In this manner, needle valve admits and shuts off fuel alternately to maintain a practically constant fuel level inside the float chamber.

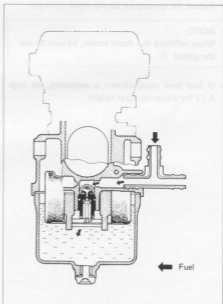

FUEL LEVEL INSPECTION

NOTE:

Before overhauling the carburetors, inspect the fuel level in the following manner.

- Place machine on center stand.
- Remove carburetor drain plug and install the fuel level gauge (1).

09913-14541

Fuel gauge set

- Run the engine at the idling speed (1250-1350 r/min), and measure the distance with the middle line of the level gauge aligned with the lower surface of carburetor body as shown in photo. (A) should be within the specified range.

Distance (A)

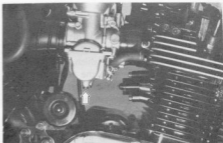
 5.0 ± 0.5 mm

- Repeat the procedure on the other cylinder.

NOTE:

When refitting the drain screw, be sure to use the gasket (2).

- If fuel level readjustment is necessary, see page 4-13 for adjusting float height.



DISASSEMBLY

- Remove the carburetor set upper plate ① by unscrewing 4 screws.

09900-09003

Impact driver set

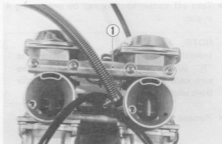

- Remove the both float chambers.
- Remove carburetor set lower plate ② by unscrewing 4 screws.

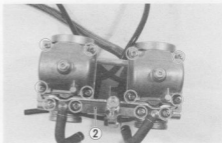

- Loosen two tightening screws ③ of the starter shaft and pull out the starter shaft to the left.

CAUTION:

These two screws are locked by applying thread lock cement. Once remove these screws, they will be replaced with new ones.

- Separate both carburetors.

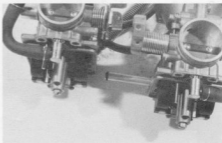
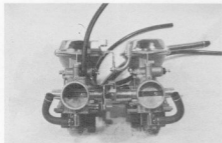
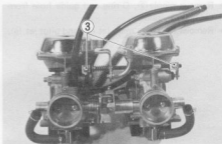

- Take off carburetor top cap by unscrewing 4 screws.

NOTE:

Identify the two piston valves removed as "R" valve and "L" valve, in order to make sure each will be restored to the carburetor from which it was taken out.

- Remove circlip ① from piston.

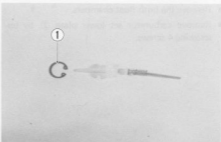
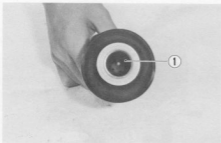
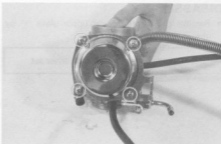

- Remove nipple ②, O-ring and guide hose from the body by pulling.
- Remove float ③, main jet ④, and pilot jet ⑤.

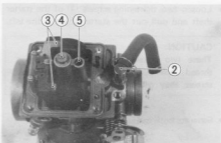

- Remove the needle valve ⑥.

CAUTION:

Use care removing the float pivot pin or damage to the carburetor body float pivot base may occur.

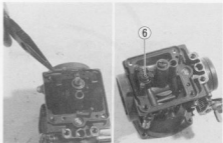

- Remove two throttle valve screws ①, and pull out the valve by turning throttle valve shaft.

CAUTION:

These two screws are locked by punching its end. Once removing the screws, they will be damaged.

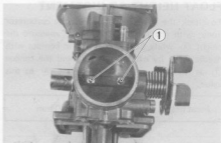

- Remove the starter valve from the carburetor body.

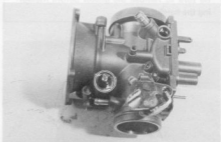

- Check following items for any damage or wear.
 - Air filter
 - Fuel filter
 - Starter valve
 - Starter air filter
 - Pilot air filter
 - Needle jet and driving hole
 - Jet
 - Needle valve/needle and O-ring
 - Diaphragm
 - Gasket and O-ring
 - Throttle cable and oil seal
 - Drain plug gasket
 - Pilot screw driving hole
 - Pilot outlet and bypass holes
 - Fuel pipe and O-ring

FLOAT HEIGHT ADJUSTMENT

To check the float height, invert the carburetor body, with the float arm kept free, measure the height **A** while float arm is just in contact with needle valve by using calipers. Bend the tongue **1** as necessary to bring the height **A** to this value.

Float height A	23.0 ± 1.0 mm
-----------------------	---------------

NOTE:

Be sure to remove the gasket before measuring the height.

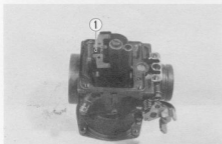
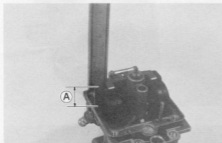

NEEDLE VALVE

If foreign matter is caught between the valve seat and the needle, the gasoline will continue to flow and result in overflowing. If the seat and needle are worn out beyond the permissible limits, similar trouble will occur. Conversely, if the needle sticks, the gasoline will not flow into the float chamber. Remove the carburetor, float chamber and floats, and clean the float chamber and float parts with gasoline. If the needle is worn as shown below, replace it together with a valve seat. Clean the fuel passage of the mixing chamber with compressed air.

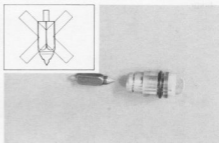

- Check following items for any damage or clogging.
 - * Pilot jet
 - * Main jet
 - * Main air jet
 - * Pilot air jet
 - * Needle jet air bleeding holes
 - * Float
 - * Needle valve mesh and O-ring
 - * Diaphragm
 - * Gasket and O-ring
 - * Throttle valve shaft oil seals
 - * Drain plug gasket
 - * Pilot screw bleeding hole
 - * Pilot outlet and bypass holes
 - * Fuel pipe and O-ring

REASSEMBLY

- Align the groove ① of the needle jet with the pin ② and replace it.

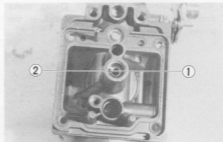

- Place tongue ③ of diaphragm into carburetor body properly.

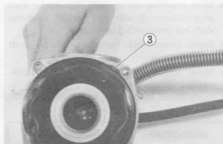

- When engaging both carburetors, be sure to fix fuel pipe ④ with O-rings properly.

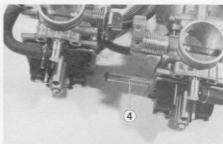

- Position throttle valve control lever ⑤ correctly.

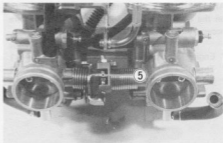

- When remounting nipple with O-ring, make sure that O-ring is properly located in the groove ①.

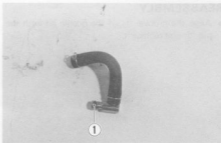

- When mounting starter shaft, align starter shaft securing screw ② with dent mark ③ on starter shaft and grease sliding portions.
- Apply thread lock cement to starter shaft securing screws.
- Apply thread lock cement to lower bracket screws.
- Apply thread lock cement to the upper bracket screws.

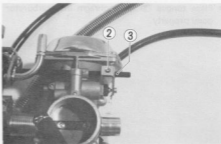

99000-32040

Thread lock cement

- Set each throttle valve in such a way that its top end ④ meets the foremost bypass ⑤. This is accomplished by turning throttle valve stop screw ⑥ and balance screw ⑦.

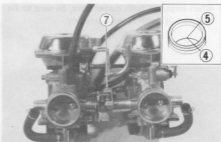

After each job is completed, mount the carburetor on the engine, and the following adjustments are necessary.

	Page
* Engine idle r/min	2 - 11
* Throttle cable play	2 - 11
* Balancing carburetors	4 - 16

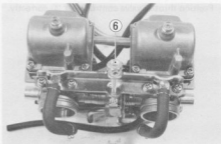

BALANCING CARBURETORS

The two carburetors must be balanced after disassembling the engine or the carburetors. As the first step, calibrate the carburetor balancer gauge as follows:

09913-13121

Carburetor balancer

- Start up the engine and run it in idling condition for warming up.
- Stop the warmed-up engine. Remove vacuum inlet screw ① for "R" cylinder and install adaptor ② with O-ring.

09913-13140

Adaptor

- Attach one of the four rubber hoses of the balancer gauge to this adaptor, and start up the engine, and keep it running at 1 750 r/min by turning throttle stop screw ③.

CAUTION:

When making this test, gear should be in "Neutral" position.

- Turn the air screw ④ of the gauge so that the vacuum acting on the tube of that hose will bring the steel ball ⑤ in the tube to the lower line ⑥.

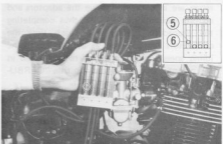
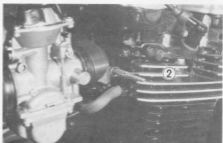

- After making sure that the steel ball stays steady at the lower line, disconnect the hose from the adaptor and connect the next hose to the adaptor. Turn air screw to bring the other steel ball ① to the lower line.
- Remove the vacuum inlet screw for "L" cylinder, and install the other adaptor.

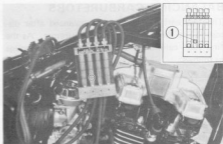

- Have the two hoses, mentioned above, connected to the two "R" and "L" adaptors. Run the engine at steady 1750 r/min and, under this running condition, see if the two steel balls stay equally at the lower level line, as they should, to signify that the two carburetors, "R" and "L", are in balance: if not, remove the carburetor assembly from the engine, and loosen lock nut and turn throttle balance screw ② to adjust the throttle valve setting in "L" carburetor. Turning the balance screw ② will tend to change engine speed; if any change is noted, restore the speed to 1750 r/min by turning the throttle stop screw.

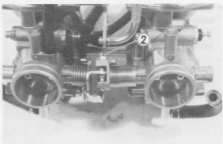
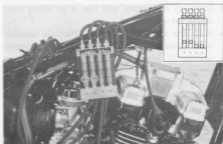

- Having checked to be sure that the two carburetors are in balance, remove the adaptors and restore vacuum inlet screws, thus completing the procedure. Remember, each time the carburetors are balanced as above, the engine idling speed setting must be re-established in the manner set forth under the title "CARBURETOR IDLE RPM" (page 2-11).

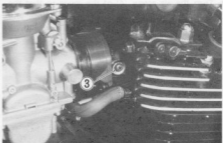
**NOTE:**

Each vacuum inlet screw has a gasket ③. Be careful not to leave out this gasket.

LUBRICATION SYSTEM

OIL PRESSURE

Start the engine and check if the oil pump pressure indicator light is turned on. If it keeps on lighting, check the oil pump pressure indicator light circuit. If it is in good condition, check the oil pump pressure in the following manner:

- Install the oil pressure gauge ① in the position shown in the figure.
- Warm up the engine as follows:
Summer approx. 10 min. at 2 000 r/min
Winter approx. 20 min. at 2 000 r/min
- After warming up operation, increase the engine speed to 3 000 r/min, and read the oil pressure gauge.
- The oil pump pressure is specified below:

Oil pump pressure:

Above 2.5 kg/cm²
Below 5.5 kg/cm² at 3 000 r/min.

09915-74510	Oil pressure gauge
09915-77330	Gauge (0 – 10 kg/cm ²)

If the pressure is too low, it means that the oil pump is internally worn or otherwise defective and needs to be replaced with a new one.

NOTE:

The recommended engine oil is, SE or SF, 10W-40 motor oil.



LUBRICATION SYSTEM CHART

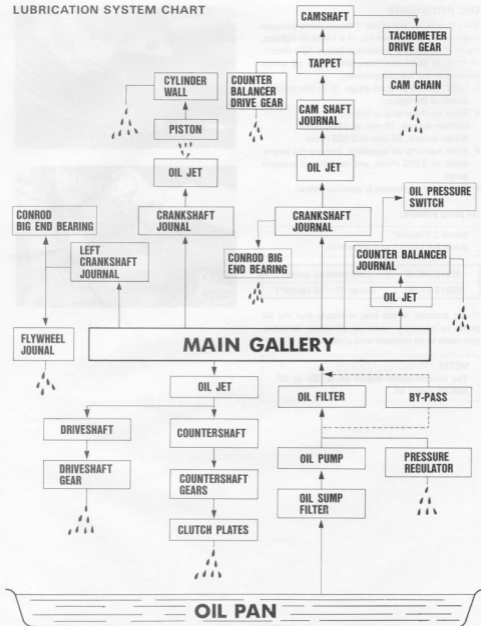

ENGINE LUBRICATION SYSTEM

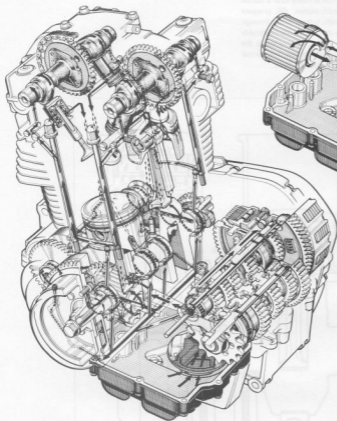

OIL PUMP COOLING

The oil pump is cooled by the oil in the oil pan. The oil in the oil pan is cooled by the oil in the oil gallery. The oil in the oil gallery is cooled by the oil in the oil filter. The oil in the oil filter is cooled by the oil in the oil pump. The oil in the oil pump is cooled by the oil in the oil pan.

The oil pump is driven by the crankshaft. The oil pump is located at the front of the engine. The oil pump draws oil from the oil pan and pumps it through a filter and into the oil gallery. The oil gallery then distributes the oil to the various parts of the engine, such as the pistons and the crankshaft.

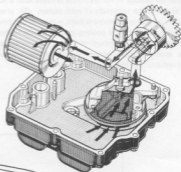

OIL JET PISTON COOLING

As an engine's horsepower is increased, so is the amount of heat which must be dissipated. The usual approach is to increase the number and size of cylinder and cylinder head fins and the thickness of these castings. SUZUKI did the unusual.

A special oil passage in the crankcase is fitted with a nozzle (jets) aimed at the underside of each piston. Oil, pressure fed by the oil pump to the crankshaft, is then forced through the nozzles and sprays a cooling stream on the underside of the pistons. This method of piston cooling keeps the engine cool, improves longevity and allows substantial weight reduction of the cylinder and cylinder head.

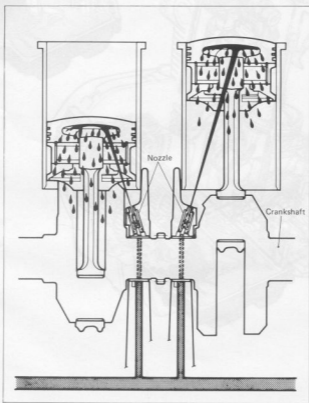

ELECTRICAL SYSTEM

CONTENTS

CHARGING SYSTEM	5- 1
IGNITION SYSTEM	5- 5
STARTER SYSTEM	5- 8
COMBINATION METER AND INSTRUMENT PANEL	5-11
LAMPS	5-12
SWITCHES	5-14
COIL TYPE FUEL GAUGE	5-17
BATTERY	5-19

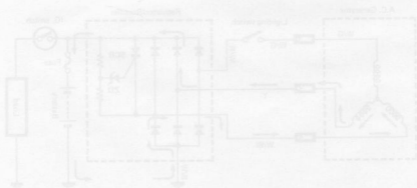

CHARGING SYSTEM

DESCRIPTION

The charging circuit is comprised of an AC generator, regulator/rectifier unit and battery as shown in the illustration.

The AC current generated is changed to DC by the rectifier so the battery can be charged.

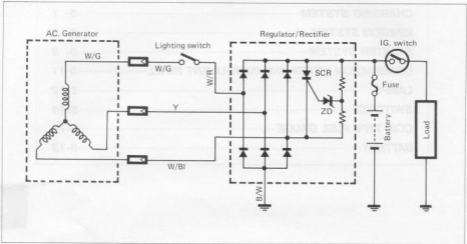

FUNCTION OF REGULATOR

When the engine r/min and the AC voltage are low, the regulator portion is inoperative and all current being generated goes directly to the battery, charging it.

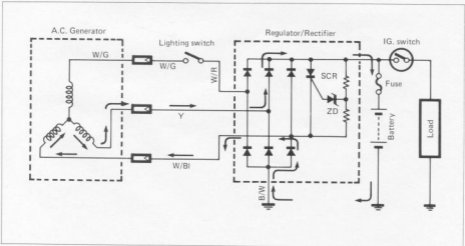

When the engine r/min becomes higher, the generated AC voltage also becomes higher and the voltage between points **A** and **B** of regulator becomes higher. When it reaches the adjusted voltage of the regulator, ZD (Zener diode) becomes conductive and the signal ① will be sent to the SCR (Thyristor) gate and SCR will become conductive.

The SCR is conductive in the direction from point **C** to point **D**. At this time the current generated from the AC generator passes through SCR without charging the battery and returns to the AC generator. At the completion of this phase the AC current generated flows to point **D** and reverse current tries to flow to SCR, then the circuit of the SCR turns to the OFF mode and begins to charge the battery again. Thus these repetitions maintain charging voltage to the battery constant and protect it from overcharging.

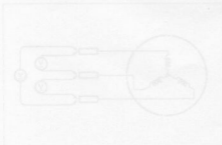
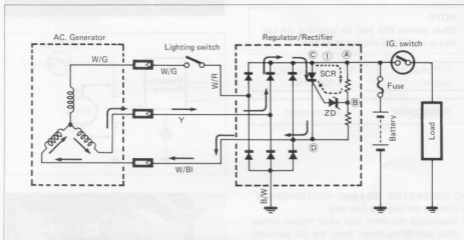

INSPECTION**CHARGING OUTPUT CHECK**

- Remove the seat.
- Start the engine and keep it running at 5 000 r/min.
- Using pocket tester, measure the DC voltage between the battery terminal \oplus and \ominus .
If the tester reads under 13.5V or over 15.5V, check the AC generator no-load performance and regulator/rectifier.

NOTE:

When making this test, be sure that the battery is in the fully-charged condition.

STD charging output	13.5 – 15.5V (DC) at 5 000 r/min
---------------------	----------------------------------

09900-25002	Pocket tester
-------------	---------------

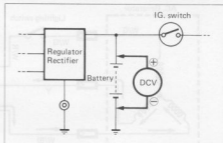
**AC GENERATOR NO-LOAD PERFORMANCE**

- Remove the seat and fuel tank.
- Disconnect the three lead wires Yellow, White/Blue and White/Green from the AC generator terminal.
- Start the engine and keep it running at 5 000 r/min. Using the pocket tester, measure the AC voltage between the three lead wires.
If the tester reads under 80V, the AC generator is faulty.

STD No-load performance	80V (AC) or Over at 5 000 r/min
-------------------------	---------------------------------

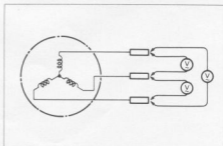

AC GENERATOR CONTINUITY CHECK

- Remove the seat and fuel tank.
- Using the pocket tester, check the continuity between the three lead wires of the stator.
- Also check that the stator core is insulated.

NOTE:

When making this test, it is not necessary to remove the AC generator.

09900-25002

Pocket tester

STD resistance

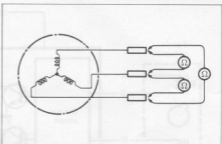
0 – 1 Ω 

REGULATOR/RECTIFIER

- Using the pocket tester (k Ω range), measure the resistance between the taps of the regulator/rectifier in the following table.

If the resistance checked is incorrect, replace the regulator/rectifier.

NOTE:

If a tester other than SUZUKI is used, the following values may vary.

09900-25002

Pocket tester

Unit: Approx. k Ω

		⊕ Probe of tester to:				
		B/W	Y	W/BI	W/R	R
① Probe of tester to:	B/W		2.5-4.0	2.5-4.0	2.5-4.0	7.0-11.0
	Y	OFF		OFF	OFF	2.5-4.0
	W/BI	OFF	OFF		OFF	2.5-4.0
	W/R	OFF	OFF	OFF		2.5-4.0
	R	OFF	OFF	OFF	OFF	

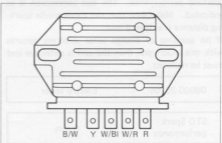

IGNITION SYSTEM

DESCRIPTION

The fully transistorized ignition system consists of a signal generator, ignitor, ignition coils, and spark plugs. The signal generator is comprised of one rotor and two pick-up coils.

The signal generator is mounted at the right end of the crankshaft. The output of the signal generator goes to the ignitor unit, where it turns ON and OFF the transistor alternately. As the transistor is turned ON and OFF, the current passing through the primary windings of the ignition coil is also turned OFF and ON accordingly, thus it induces the secondary current in the ignition coil secondary windings and produce the spark between spark plug gaps.

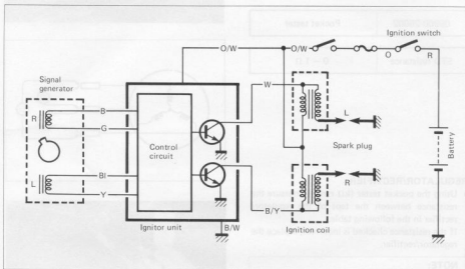

INSPECTION

IGNITION COILS (Checking with Electro Tester)

Using the electro tester, test each ignition coil for sparking performance. The test connection is as indicated. Make sure that the three-needle sparking distance is at least 8 mm.

If no sparking or orange color sparking occurs with this much gap, then the coil is defective and must be replaced.

09900-28106	Electro tester
-------------	----------------

STD Spark performance	8 mm
-----------------------	------

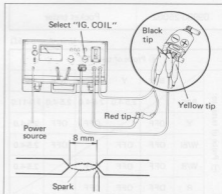

IGNITION COILS (Checking with Pocket Tester)

A SUZUKI pocket tester or an ohm meter may be used, instead of the electro tester. In either case, the ignition coil is to be checked for continuity in both primary and secondary windings. Exact ohmic readings are not necessary, but, if the windings are in sound condition, their continuity will be noted with these approximate ohmic values.

09900-25002	Pocket tester
-------------	---------------

Ignition coil resistance

Primary (+ - -)	3 - 5 Ω
Secondary (plug cap - -)	20 - 30 k Ω

NOTE:

+ terminal is a larger width than - terminal.

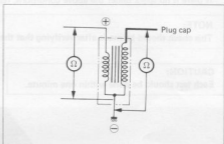
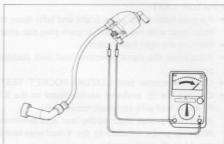
**SIGNAL GENERATOR**

Disconnect the coupler from the ignitor and measure the resistance between lead wires.

If the resistance noted shows infinity or too low of a resistance value, the signal generator must be replaced.

09900-25002	Pocket tester
-------------	---------------

Standard resistance

B - G	450 - 650 Ω
BI - Y	

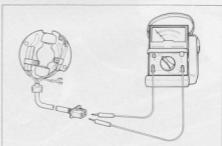

IGNITOR UNIT

- Remove both spark plugs (right and left) from the cylinder head, and place both spark plugs on the cylinder head with the respective spark plug cap attached as shown in the fig.
- Remove the right frame cover.
- Disconnect the signal generator lead wire coupler from the ignitor. Turn the ignition switch to the ON position.
- Using the special tool (SUZUKI POCKET TESTER), check the ignitor unit. (Set the tester to RX1)
- Connect the \oplus probe of pocket tester to the B lead wire terminal of the ignitor and \ominus probe to the Y, BI and G lead wire terminals respectively.

When both probes touch to the lead wire terminals, the right spark plug should spark.

When \oplus probe switches to the Y lead wire terminal and \ominus probe to the B, BI and G, the left spark plug should spark continuously.

If there is no spark under the above conditions, replace the ignitor unit with a new one.

NOTE:

This check should be made after verifying that the ignition coil is good.

CAUTION:

Each test should be done within one minute.



STARTER SYSTEM

DESCRIPTION

The starter system is shown in the diagram below: namely, the starter motor, relay, starter button, engine kill switch, ignition switch and battery. Depressing the starter button (on the right handlebar switch box) energizes the relay, causing the contact points to close which connects the starter motor to the battery. The motor draws about 80 amperes to start the engine.

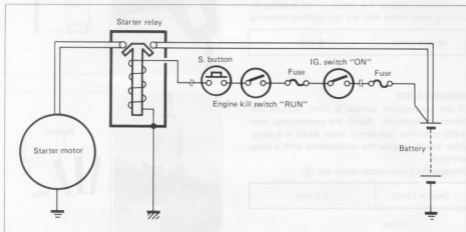

STARTER MOTOR REMOVAL AND DISASSEMBLY

Remove the starter motor (See page 3-16).

Disassemble the starter motor as follows.

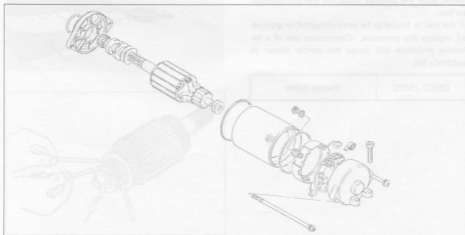

STARTER MOTOR INSPECTION

CARBON BRUSHES

When the brushes are worn, the motor will be unable to produce sufficient torque, and the engine will be difficult to turn over. To prevent this, periodically, inspect the length of the brushes, replacing them when they are too short or chipping.

Service Limit	6 mm
---------------	------

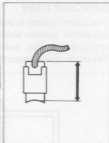

COMMUTATOR

If the commutator surface is dirty, starting performance decreases. Polish the commutator with #400 or similar fine emery paper when it is dirty. After polishing wipe the commutator with a clean dry cloth.

Measure the commutator under-cut ①.

Service Limit	0.2 mm
---------------	--------

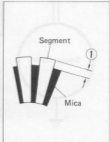

ARMATURE COIL

Using a pocket tester, check the coil for open and ground by placing probe pins on each commutator segment and rotor core (to test for ground) and on any two segments at various places (to test for open), with the brushes lifted off the commutator surface.

If the coil is found to be open-circuited or grounded, replace the armature. Continuous use of a defective armature will cause the starter motor to suddenly fail.

09900-25002	Pocket tester
-------------	---------------

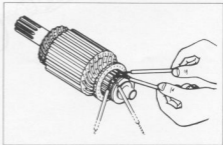
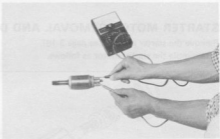

STARTER MOTOR REASSEMBLY

BRUSH HOLDER

When fixing brush holder to starter motor case, align the protrusion ① of the starter motor case with the notch ② of the brush holder.

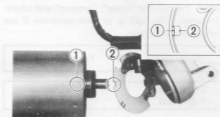

HOLDER END

When installing housing end, fix the protrusion ① of the starter motor case to the notch ② on the housing end.

HOUSING TOP

When installing housing top, fix the protrusion ③ of starter motor case to the notch ④ on the housing top.

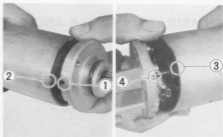

SECURING SCREWS

Apply thread lock "1342" to starter motor securing screws.

99000-32050	Thread lock "1342"
-------------	--------------------

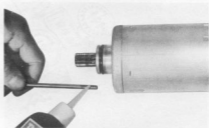

STARTER RELAY INSPECTION

Disconnect lead wire of the starter motor at starter relay.

Turn on the ignition switch, and inspect the continuity between the terminals, positive and negative with pocket tester, when pushing the starter button.

If the starter relay is in sound condition, continuity is found.

09900-25002	Pocket tester
-------------	---------------



Check the coil for "open", "ground" and ohmic resistance. The coil is in good condition if the resistance is as follows.

09900-25002	Pocket tester
STD resistance Y/G - B/W	3 - 4 Ω



COMBINATION METER AND INSTRUMENT PANEL

Remove the combination meter (See page 6-20).
Disassemble the combination meter as follows.

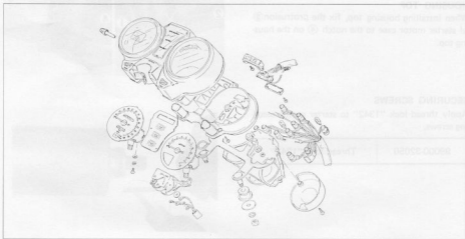

INSPECTION

Using pocket tester, check the continuity between lead wires in the following diagram.
If the continuity checked is incorrect, replace the respective part.

09900-25002	Pocket tester
-------------	---------------

NOTE:

When making this test, it is not necessary to remove the combination meter.

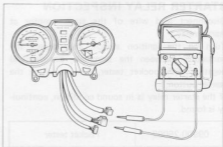

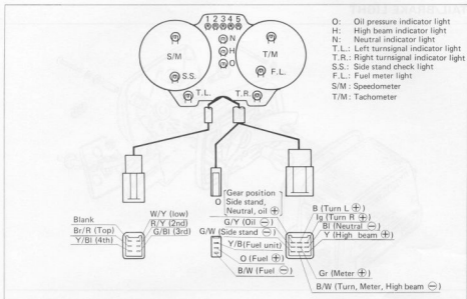

LAMPS HEADLIGHT

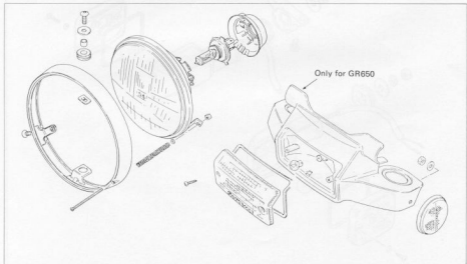

TAIL/BRAKE LIGHT

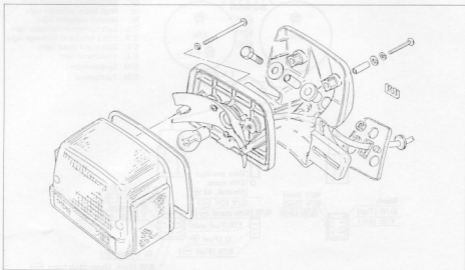

TURN SIGNAL LIGHT

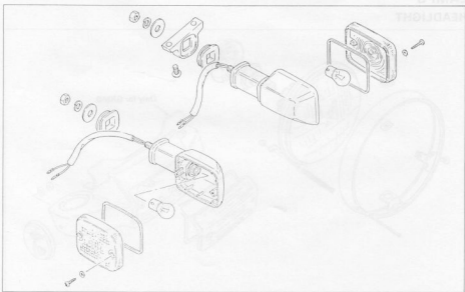

SWITCHES

Inspect each switch for continuity with pocket tester referring to the chart.
If any abnormality is found, replace the respective switch assembly with a new one.

09900-25002

Pocket tester

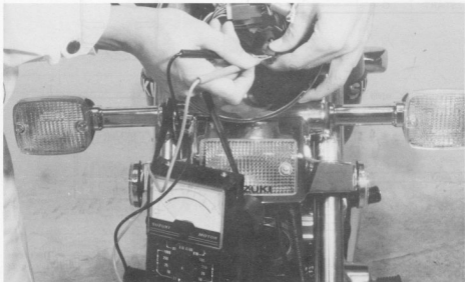

IGNITION SWITCH

	R	O	Gr	Br
OFF				
ON	○ — ○		○ — ○	
P	○ — ○			○ — ○

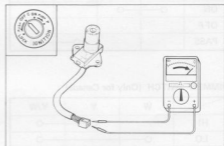

	L	B	R
L	○ — ○		
B		○ — ○	
R			○ — ○

ENGINE KILL AND STARTER SWITCHES

	O/W	O	Y/G
OFF			
RUN	○	○	
START	○		○

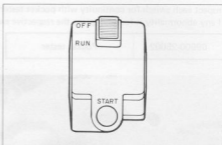

TURN SIGNAL AND DIMMER SWITCHES

	B	Lbl	Lg
R		○	○
•			
L	○	○	

	W	Y	Y/W
HI		○	○
LO	○		○

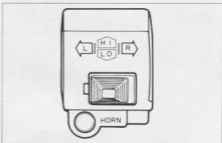

HORN SWITCH

	B/W	G	Bl/W
ON	○	○	
OFF			
PASS			○

HORN SWITCH

—— The others
 - - - - Only for E34

	B/W	G	O/R
ON	○	○	
OFF			
PASS			○

DIMMER SWITCH (Only for Canada)

	W	Y	Y/W
HI		○	○
LO	○		○

HORN SWITCH (Only for Canada)

	B/W	G
ON	○	○
OFF		

TURN SIGNAL LIGHT SWITCH

(Only for Canada)

	B	Lbl	Lg
R		○	○
•			
L	○	○	

FRONT BRAKE SWITCH

	O	W
ON	○	○
OFF		

REAR BRAKE LIGHT SWITCH

	O	W
ON	○	○
OFF		

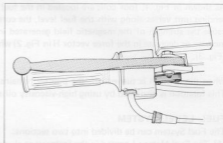

GEAR POSITION INDICATOR SWITCH

	Ground	W/Y	Bl	R/B	G/Bl	Y/Bl	Br/R
Low	○	○					
Neutral	○		○				
2nd	○			○			
3rd	○				○		
4th	○					○	
Top	○						○

SIDE STAND CHECK LIGHT SWITCH
(Except E16, 18, 22, 26)

	G/W	B/W
ON	○	○
OFF		



OIL PRESSURE SWITCH

- Continuity, when engine is stopped.
- No continuity, when engine is running.

NOTE:

Before testing the oil pressure switch, check the engine oil level.



COIL TYPE FUEL GAUGE

As shown in Fig. 1, four coils are located in the fuel gauge (N_1 , N_2 , N_3 and N_4). As the resistance from the sending unit varies along with the fuel level, the current at points L_1 and L_2 will also vary. This in turn will cause the strength of the magnetic field generated in the four coils to increase or decrease (causing a related increase or decrease in the force vector H in Fig. 2) which will force the needle to move to the proper position (Fig. 3).

When the ignition is turned off, the pointer remains in the position where it was when the switch was ON. This function is displayed by using high-viscosity oil and a balanced magnet (Fig. 4).

FUEL LEVEL SYSTEM

The Fuel System can be divided into two sections:

- (1) The Fuel Meter : Located in the instrument cluster
- (2) The Fuel Tank Float Assembly (Fuel gauge sending unit)

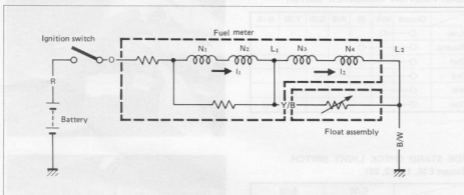

Fig. 1

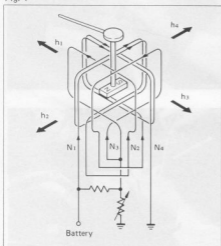

Fig. 3

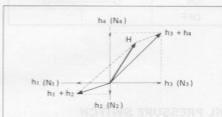

Fig. 2

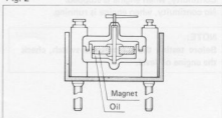

Fig. 4

NOTE:

Prior to testing the Fuel Level system, verify that the battery is in a fully charged condition.

FUEL METER INSPECTION

To test the Fuel Meter two different checks may be used. The first, and simplest test will tell if the meter is operating but will not indicate the meters accuracy throughout the range.

To perform this test, disconnect the B/W and Y/B lead wire of the fuel meter and the ground lead wire. Connect a jumper wire between B/W and Y/B wires coming from the main wiring harness. With the ignition switch turned on, the fuel meter should indicate "F".

The second test will check the accuracy of the meter in the full and empty positions.

Connect a 95-ohm resistor between the Y/B lead wire of the fuel gauge and the ground lead wire. The fuel gauge is normal if its pointer indicates the E (empty) position when the specified voltage is applied to the circuit and if its pointer indicates the F (full) position when the resistor is changed to 7 ohms. If either one or both indications are abnormal, replace the fuel meter with a new one.

FUEL GAUGE SENDING UNIT

- Remove the lead wires coming out of the fuel gauge and check resistance of each of them.
- If the resistance measured is incorrect, replace the fuel gauge assembly with a new one.
- The relation between position of the fuel gauge float, resistance, and fuel quantity is shown in the following table.

Float position	Resistance	Fuel quantity
F	5 – 10 Ω	Approx. 10.5L
1/2	30 – 35 Ω	Approx. 7.5L
E	90 – 105 Ω	Approx. 1.0L

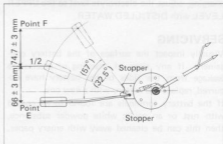
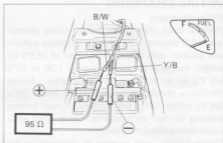
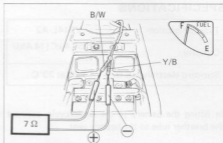

BATTERY

SPECIFICATIONS

Type designation	YB14L-A2
Capacity	12V, 50.4 kC (14 Ah)/ 10 HR
Standard electrolyte S.G.	1.28 at 20°C

In fitting the battery to the motorcycle, connect the breather tube to the battery vent.

INITIAL CHARGING

Filling electrolyte

Remove short sealed tube before filling electrolyte. Fill battery with electrolyte (dilute sulfuric acid solution with acid concentration of 35.0% by weight, having a specific gravity of 1.28 at 20°C (68°F)) up to indicated UPPER LEVEL. Filling electrolyte should be always cooled below 30°C (86°F) before filling into battery. Leave battery standing for half an hour after filling. Add additional electrolyte if necessary.

Charge battery with current as described in the tables shown below.

Maximum charging current	1.4A
--------------------------	------

Charging time

The charging time for a new battery is determined by the number of months that have elapsed since the date of manufacture.

Date of manufacture is indicated by a three-part number ①, as follows, each indicating month, date and year.

Near the end of charging period, adjust the specific gravity of electrolyte to value specified. After charging, adjust the electrolyte level to the UPPER LEVEL with DISTILLED WATER.

SERVICING

Visually inspect the surface of the battery container. If any signs of cracking or electrolyte leakage from the sides of the battery have occurred, replace the battery with a new one.

If the battery terminals are found to be coated with rust or an acidic white powder substance, then this can be cleaned away with emery paper.

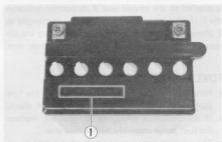
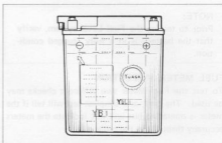

Months after manufacturing	Within 6	Within 9	Within 12	Over 12
Necessary charging hours	20	30	40	60

Check the electrolyte level and add distilled water, as necessary, to raise the electrolyte to each cell's upper level.

Check the battery for proper charge by taking an electrolyte S.G. reading. If the reading is 1.22 or less, as corrected to 20°C (68°F), it means that the battery is still in a discharge condition and needs recharging.

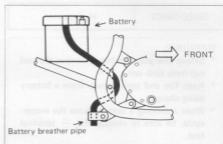

BASED ON S.G. READING RECHARGING OPERATION

To correct an S.G. reading 20°C (68°F), use the table at the right.

To read the S.G. on the hydrometer, bring the electrolyte in the hydrometer ① to eye level and read the graduations on the float scale bordering on the meniscus (curved-up portion of electrolyte surface), as shown in figure.

Check the reading (as corrected to 20°C) with chart to determine the recharging time in hours by constant-current charging at a charging rate of 1.4 amperes (which is a tenth of the capacity of the present battery).

Be careful not to permit the electrolyte temperature to exceed 45°C (113°F), at any time, during the recharging operation. Interrupt the operation, as necessary, to let the electrolyte cool down. Recharge the battery to the specification.

Electrolyte specific gravity	1.28 at 20°C (68°F)
------------------------------	---------------------

CAUTION:

Constant-voltage charging, otherwise called "quick" charging, is not recommended as it could shorten the life of the battery.

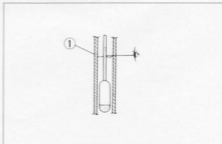
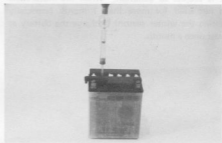
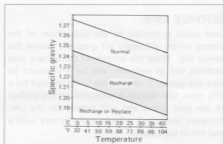

09900-28403

Hydrometer

WARNING:

- * Before charging a battery, remove the seal cap from each cell.
- * Keep fire and sparks away from a battery being charged.
- * When removing a battery from the motorcycle, be sure to remove the \ominus terminal first.

SERVICE LIFE

Lead oxide is applied to the pole plates of the battery which will come off gradually during the service life. When the bottom of the battery case becomes full of sediment, the battery cannot be used any more. If the battery is not charged for a long time, lead sulfate is generated on the surface of the pole plates and will deteriorate the performance (sulfation). Replace the battery with a new one in such a case.

When a battery is left for a long term without use, it is subject to sulfation. When the motorcycle is not used for more than 1 month (especially during the winter season), recharge the battery at least once a month.

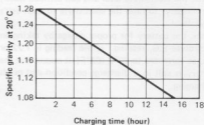
**RECHARGING OPERATION BASED ON S.G. READING**

To correct an S.G. reading to 20°C (68°F), use the following formula:

To test the S.G. on the hydrometer, bring the electrolyte to the temperature (20°C) and read the hydrometer on the first scale reading and the second reading is the average of the two readings.

Check the reading and compare to 20°C with the following table. The charging time is found by the amount of current charging at a charging rate of 1.8 amperes (which is a half of the capacity of the battery).

Be careful not to permit the electrolyte temperature to exceed 45°C (113°F) at any time during the recharging operation. Sulfation may occur if necessary to let the electrolyte cool down through the battery in the operation.

Electrolyte specific gravity	1.28 to 20°C (68°F)
------------------------------	---------------------

CAUTION:
Overcharge or over-discharge is not recommended as "cable" charging is not recommended as it could shorten the life of the battery.

CHASSIS

CONTENTS

FRONT WHEEL	6- 1
FRONT BRAKE	6- 5
FRONT FORK	6-13
STEERING STEM	6-19
REAR WHEEL	6-24
TIRE AND WHEEL	6-31
REAR BRAKE	6-37
REAR SWING ARM AND SUSPENSION	6-40

FRONT WHEEL

CONSTRUCTION

SPOKE TYPE

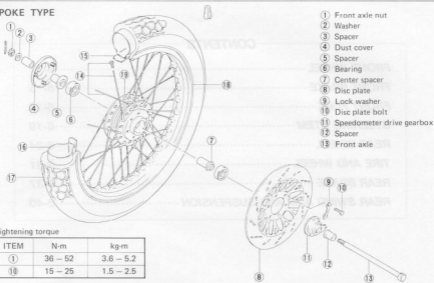

CAST WHEEL TYPE

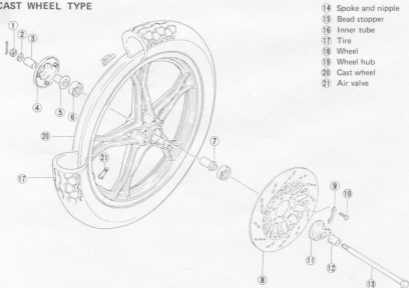

REMOVAL AND DISASSEMBLY

- Support the machine by center stand and jack.

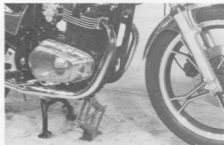

- Remove caliper mounting bolts and dismount the caliper.

NOTE:

Do not operate the brake lever while dismounting the caliper.

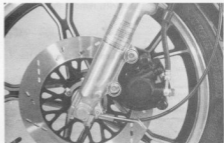

- Pull out cotter pin and remove axle nut.
- Remove axle holders.



- Draw out axle shaft and take off front wheel.

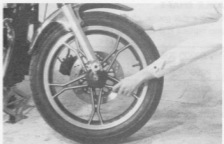

- Unlock the lock washer.
- Remove the securing bolts and separate the disc from wheel.

CAUTION:

Do not reuse the lock washer.



- Using an appropriate drift, remove the right and left wheel bearings.

NOTE:

Removing the left side bearing first makes the job easier.

CAUTION:

The removed bearing should be replaced.

**INSPECTION****WHEEL BEARINGS**

Inspect the play of wheel bearing inner race by hand while fixing it in the wheel.

Rotate the inner race by hand to inspect whether abnormal noise occurs or it rotates smoothly. Replace the bearing if there is anything unusual.

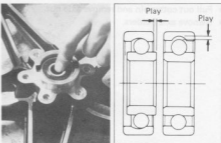
**AXLE SHAFT**

Using a dial gauge, check the axle shaft for runout and replace it if the runout exceeds the limit.

09900-20606	Dial gauge (1/100)
09900-20701	Magnetic stand
Service Limit	0.25 mm

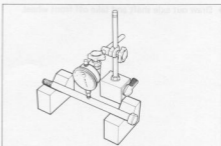

WHEEL RIM

Make sure that the wheel rim runout does not exceed the service limit when checked as shown. An excessive amount of runout is usually due to loose spokes or bent rim.

If properly tightening the spokes will not correct the runout, replace the wheel rim.

In case of cast type wheel, replace the wheel assembly if the runout reading exceeds the service limit.

NOTE:

Worn or loose wheel bearings must be replaced before attempting to true a wheel rim.

Service Limit (Axial and Radial)	2.0 mm
-------------------------------------	--------

REASSEMBLY

Reassemble and remount the front wheel in the reverse order of disassembly and removal, and also carry out the following steps:

WHEEL BEARING

Apply grease before installing the bearings.

99000-25010	SUZUKI super grease "A"
-------------	-------------------------

Install the wheel bearings as follows by using the special tool.

CAUTION:

First install the wheel bearing for left side.

09924-84510	Bearing installer set
-------------	-----------------------

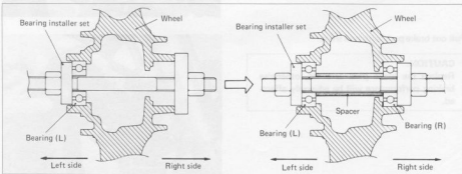
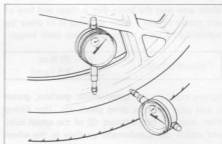

Make sure that the brake disc is clean and free of any greasy matter. After securing it in place by tightening its bolts, be sure to lock each tongue.

Tightening torque	15 – 25 N·m (1.5 – 2.5 kg·m)
-------------------	---------------------------------

Before installing the speedometer gearbox, grease it and align the two drive pawls ① (for fitting them into the two recesses ② of the wheel hub) and attach the speedometer gearbox to the wheel hub.

When tightening the front axle, check to be sure that the speedometer gearbox is in the position so that the speedometer cable does not bend sharply.

TIGHTENING TORQUE

	N·m	kg·m
Axle nut	36 – 52	2.6 – 5.2
Axle holder nut	15 – 25	1.5 – 2.5

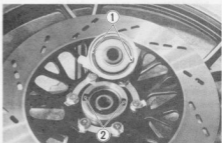

FRONT BRAKE

BRAKE PAD REPLACEMENT

Remove caliper axle bolts and take off caliper.

CAUTION:

Do not operate the brake lever while dismounting the caliper.



Pull out brake pads with pad shim.

CAUTION:

Replace the brake pads as a set, otherwise braking performance will be adversely affected.

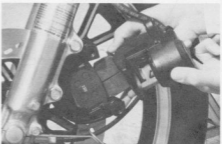

Apply silicone grease to both caliper axles lightly.

99000-25100

SUZUKI silicone grease

NOTE:

Push the piston all the way into the caliper and remount the caliper.

Caliper axle bolt
tightening torque

15 – 20 N·m
(1.5 – 2.0 kg·m)

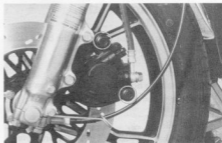
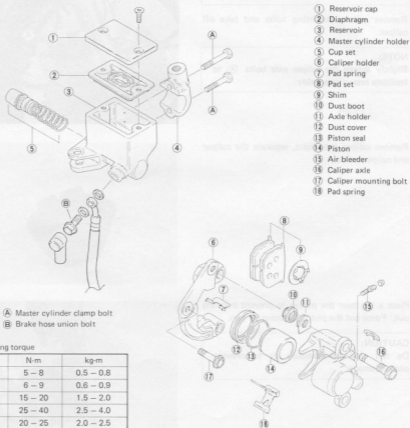
**CONSTRUCTION (MASTER CYLINDER AND CALIPER)**

CALIPER REMOVAL AND DISASSEMBLY

- Disconnect brake hose and catch the brake fluid in a suitable receptacle.

CAUTION:

Never re-use the brake fluid left over from the last servicing and stored for long periods.

WARNING:

Brake fluid, if it leaks, will interfere with safe running and discolor painted surfaces. Check the brake hose for cracks and hose joint for leakage before riding.

- Remove caliper mounting bolts and take off caliper.

NOTE:

Slightly loosen the caliper axle bolts **(A)** to facilitate later disassembly.

- Remove caliper axle bolts, separate the caliper and caliper holder.

- Place a rag over the piston to prevent popping out. Force out the piston by using air gun.

CAUTION:

Do not use high pressure air to prevent piston damage.

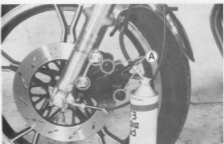

- Remove dust boot and piston seal.

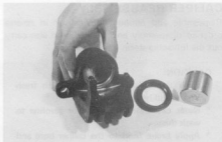

CALIPER AND DISC INSPECTION

- Inspect the caliper bore wall for nicks, scratches or other damage.
- Inspect the each rubber parts for damage and wear.
- Inspect the piston surface for any scratches or other damage.

Using a micrometer check the disc for wear. Its thickness can be checked with disc mounted on the wheel. The service limit for the thickness of the disc:

09900-20205	Micrometer (0 – 25 mm)
-------------	------------------------

Service Limit	4.5 mm
---------------	--------

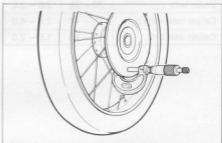

With the disc mounted on the wheel, check the disc face for runout with a dial gauge, as shown.

09900-20606	Dial gauge (1/100 mm)
09900-20701	Magnetic stand

Service Limit	0.30 mm
---------------	---------

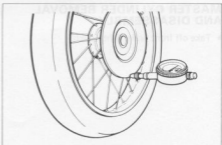

CALIPER REASSEMBLY

Reassemble and remount the caliper in reverse order of disassembly and removal, and also carry out the following steps:

CAUTION:

- Wash the caliper components with fresh brake fluid before reassembly.
- Never use cleaning solvent or gasoline to wash them.
- Apply brake fluid to the caliper bore and piston to be inserted into the bore.

Apply SUZUKI silicone grease to the caliper axles.

99000-25100

SUZUKI silicone grease

WARNING:

Bleed the air after reassembling caliper (See page 2-17).

Tightening torque:

	N·m	kg·m
Union bolt	20 – 25	2.0 – 2.5
Caliper mounting bolt	25 – 40	2.5 – 4.0
Caliper axle bolt	15 – 20	1.5 – 2.0



MASTER CYLINDER REMOVAL AND DISASSEMBLY

- Take off front brake light switch.

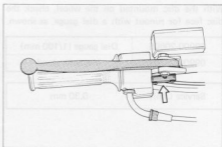

- Place a cloth underneath the union bolt on the master cylinder to catch spilled drops of brake fluid. Unscrew the union bolt and disconnect the brake hose/master cylinder joint.

CAUTION:

Completely wipe off any brake fluid adhering to any part of motorcycle. The fluid reacts chemically with paint, plastics, rubber materials, etc.

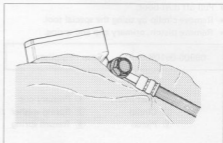

- Remove the two clamp bolts and take off master cylinder assembly.

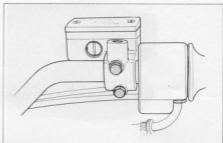

- Remove the front brake lever.
- Remove reservoir cap and diaphragm.
- Drain brake fluid.

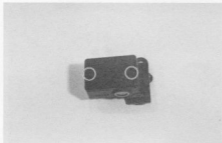
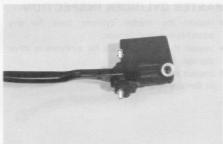

- Pull off dust boot.
- Remove circlip by using the special tool.
- Remove piston, primary cup and spring.

09900-06108

Snap ring pliers

- | | |
|-------------|-----------------|
| ① Dust boot | ④ Primary cup |
| ② Circlip | ⑤ Spring washer |
| ③ Piston | ⑥ Return spring |

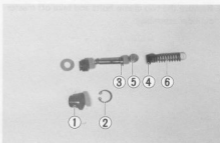
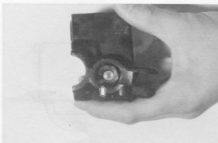

MASTER CYLINDER INSPECTION

- Inspect the master cylinder bore for any scratches or other damage.
- Inspect the piston surface for scratches or other damage.
- Inspect the primary cup and dust boot for wear or damage.

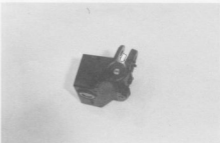
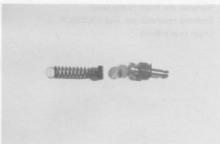

MASTER CYLINDER REASSEMBLY

Reassemble and remount the master cylinder in the reverse order of disassembly and removal, and also carry out the following steps:

CAUTION:

Wash the master cylinder components with fresh brake fluid before reassembly. Never use cleaning solvent or gasoline to wash them. Apply brake fluid to the cylinder bore and all the internals to be inserted into the bore.

When remounting the master cylinder on the handlebars, secure the clamp so that the clearances $\text{\textcircled{A}}$ of both the top and bottom of the handlebars stay equally.

CAUTION:

Bleed the air after reassembling master cylinder. (See page 2-17).
Adjust the front brake light switch after installation.

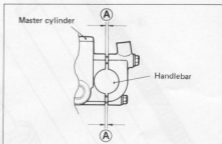

mm	in	mm	in
5.5 - 6.1	0.21 - 0.24	5.5 - 6.1	0.21 - 0.24
5.5 - 6.1	0.21 - 0.24	5.5 - 6.1	0.21 - 0.24

FRONT FORK

DISASSEMBLY

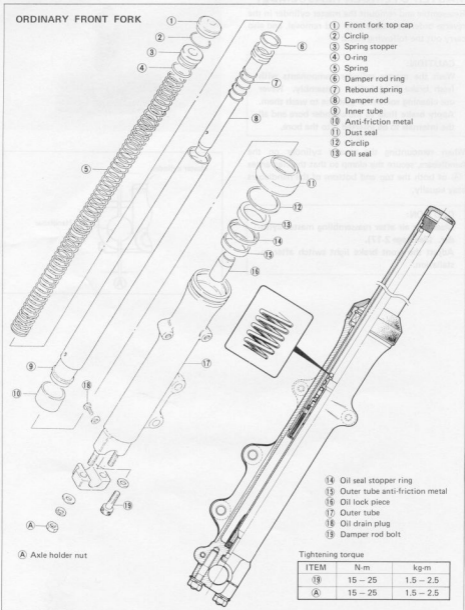

ONLY FOR CANADA

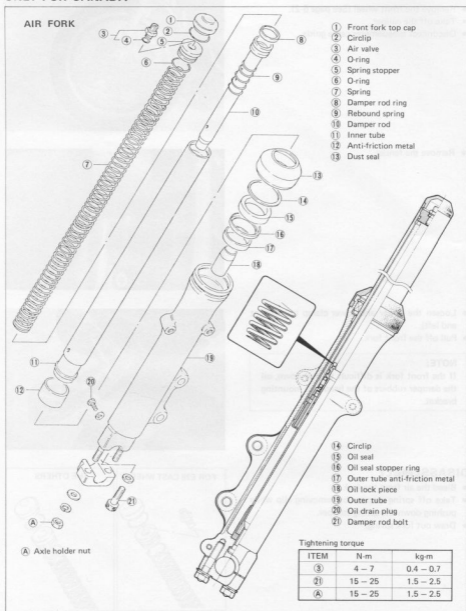

REMOVAL

- Remove the front wheel (See page 6-2).
- Take off the caliper.
- Disconnect speedometer cable guide.



- Remove the fender.



- Loosen the upper and lower clamp bolts (right and left).
- Pull off the front fork.

NOTE:

If the front fork is difficult to pull down, oil the damper rubbers of the headlight mounting bracket.

**DISASSEMBLY**

- Bleed the air from the fork.
- Take off spring stopper by removing clip while pushing down the spring stopper.
- Draw out fork spring.

Length	Part No.	MT11
10-2.0	1-3	20
11-2.1	24-31	25
12-2.1	32-37	30

FOR E28 CAST WHEEL



THE OTHERS



- Invert the fork and stroke it several times to remove the oil inside.
- Hold the fork inverted for a few minutes to drain the oil.

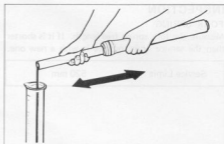

- Remove damper rod securing bolt by using the special tools.
- Draw out damper rod and rebound spring.

09940-34520	"T" handle
09940-34530	Attachment "A"
09914-25811	"T" type hexagon wrench

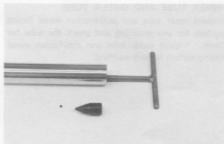

- Draw out dust seal.
- Remove circlip by using the special tool.

09900-06105	Snap ring pliers
-------------	------------------



- While holding the caliper mounting portion of the outer tube by vise, separate the inner tube from the outer tube as shown.

CAUTION:

The outer tube and inner tube "anti-friction" metals must be replaced along with the oil seal any time the front fork is disassembled.

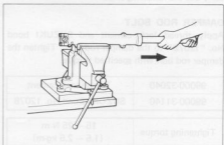

INSPECTION**FORK SPRING**

Measure the fork spring free length. If it is shorter than the service limit, replace it with a new one.

Service Limit	520 mm
---------------	--------

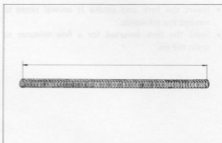
**INNER TUBE AND OUTER TUBE**

Inspect inner tube and anti-friction metal fitting surface for any scuffing and check the tube for bend. Inspect outer tube and anti-friction metal fitting surface for any scuffing.

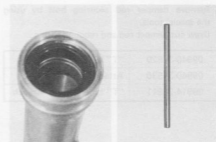
**DAMPER ROD RING**

Inspect damper rod ring for wear and damage.

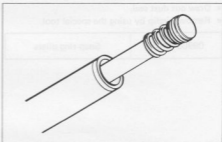
**REASSEMBLY**

Reassemble and remount the front fork in the reverse order of disassembly and removal, and also carry out the following steps:

DAMPER ROD BOLT

Apply thread lock cement and SUZUKI bond No. "1207B" to the damper rod bolt. Tighten the damper rod bolt with specified torque.

99000-32040	Thread lock cement
99000-31140	SUZUKI Bond No. 1207B

Tightening torque	15 – 25 N·m (1.5 – 2.5 kg·m)
-------------------	---------------------------------

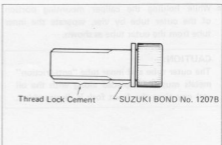

SPACER AND OIL SEAL

Clean the metal groove of the outer tube. Oil the anti-friction metal outer surface and clean the spacer and new oil seal surface, and install them to the outer tube as shown.

09940-50112	Front fork oil seal installer
-------------	-------------------------------

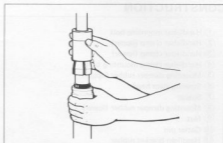
**FORK OIL**

For the fork oil, be sure to use a fork oil whose viscosity rating meets specifications below.

Fork oil type	Fork oil #15
---------------	--------------

Fork oil capacity	E28 Cast wheel	263 ml
	The others	235 ml

Hold the front fork vertical and adjust the fork oil level with the special tool.

NOTE:

When adjusting oil level, remove the fork spring and compress the inner tube fully.

09943-74111	Fork oil level gauge
-------------	----------------------

STD oil level	E28	125.3 mm
	Cast wheel	
	The others	170 mm

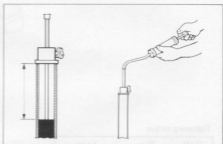
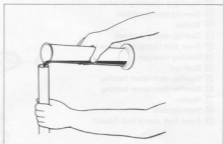
**FORK SPRING**

When installing the fork spring, tapered end should position in bottom.

Tightening torque:

	N·m	kg·m
Front fork clamp bolt (Upper)	20 – 30	2.0 – 3.0
Front fork clamp bolt (Lower)	15 – 25	1.5 – 2.5
Damper rod bolt	15 – 25	1.5 – 2.5

FRONT FORK AIR ADJUSTMENT

(Only for E28 Cast wheel)

Refer to page 2-20.

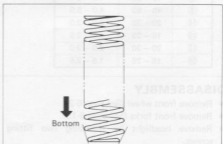

STEERING STEM

CONSTRUCTION

- ① Handlebar mounting bolt
- ② Handlebar clamp (upper)
- ③ Handlebar clamp (lower)
- ④ Handlebar clamp mounting bolt
- ⑤ Mounting damper rubber (upper)
- ⑥ Steering stem head
- ⑦ Spacer
- ⑧ Mounting damper rubber (lower)
- ⑨ Nut
- ⑩ Cotter pin
- ⑪ Headlight bracket rubber
- ⑫ Headlight bracket ring
- ⑬ Headlight mounting bracket
- ⑭ Steering stem head bolt
- ⑮ Washer
- ⑯ Steering stem clamp nut
- ⑰ Front fork clamp nut (upper)
- ⑱ Steering stem nut
- ⑲ Dust seal
- ⑳ Steering stem upper bearing
- ㉑ Steering stem lower bearing
- ㉒ Washer
- ㉓ Steering stem
- ㉔ Front fork clamp bolt (lower)

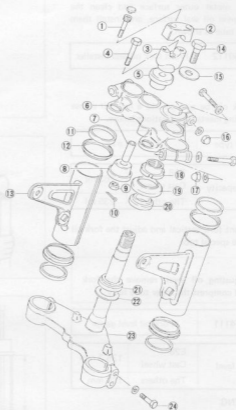

Tightening torque

ITEM	N·m	kg·m
①	12 - 20	1.2 - 2.0
⑨	40 - 60	4.0 - 6.0
⑭	20 - 30	2.0 - 3.0
⑯	15 - 25	1.5 - 2.5
⑰	20 - 30	2.0 - 3.0
㉔	15 - 25	1.5 - 2.5

DISASSEMBLY

- Remove front wheel (See page 6-2).
- Remove front forks (See page 6-15).
- Remove headlight by removing two fitting screws.



- Disconnect lead wires.
- Dismount the headlight housing, turn signal light and headlight bracket at the same time.

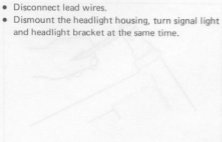

- Disconnect speedometer and tachometer cables.
- Remove meter mounting nuts and take off meter.

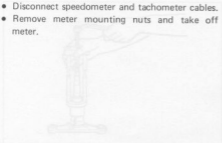

- Disconnect brake hose joint.
- Remove ignition switch by using the special tool.

09911-73730

T type hexagon wrench
(5 mm)

- Remove mounting bolts and take off handlebars.
- Remove the cotter pins and handlebar clamp mounting nuts (1).
- Loosen the steering stem clamp bolt.
- Remove steering stem head bolt and take off steering stem upper bracket.

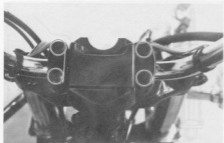

- Take off the washer.
- Remove steering stem nut by using the special tool.

NOTE:

Hold the steering stem lower bracket by hand to prevent dropping.

09940-14911

Steering nut socket wrench

- Remove the dust seal.
- Draw out lower steering stem bearing by using the special tool.

CAUTION:

The removed bearing should be replaced.

09941-84510

Bearing remover

- Push out steering stem bearing outer races, upper and lower, by using the special tools.

09941-54911

Steering race remover

09941-74910

Steering bearing installer

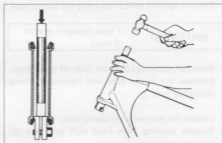
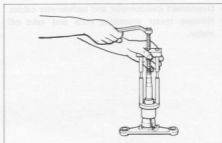
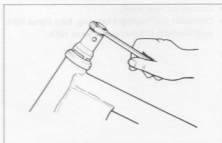
**REASSEMBLY**

Reassemble and remount the steering stem in the reverse order of disassembly and removal, and also carry out the following steps:

OUTER RACES

Press in the upper and lower outer races using the special tool.

09941-34513

Steering outer race installer

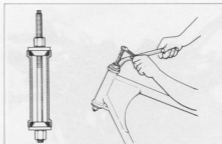

BEARING

Place a washer and press in the lower bearing by using the special tool.

09941-74910

Steering bearing installer

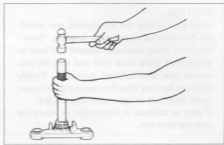

Apply grease to the upper and lower bearing races before remounting the steering stem.

99000-25010

SUZUKI super grease "A"

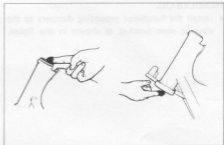
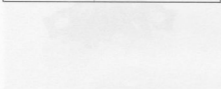
**STEM NUT**

Fit the oil seal to the stem nut.

Tighten the steering stem nut to 40 – 50 N·m (4.0 – 5.0 kg·m).

09940-14911

Steering nut socket wrench

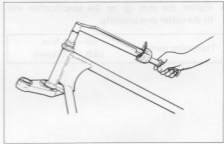
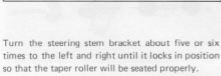

Turn back the stem nut by $\frac{1}{4}$ – $\frac{1}{2}$ turn.

NOTE:

This adjustment will vary from motorcycle to motorcycle.

Steering stem head bolt should be tightened to the specified torque.

Tightening torque

20 – 30 N·m
(2.0 – 3.0 kg·m)

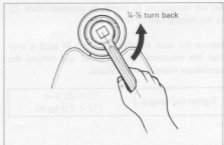

CAUTION:

After performing the adjustment and installing the steering stem upper bracket, "rock" the front wheel assembly forward and back to ensure that there is no play and that the procedure was accomplished correctly. Finally check to be sure that the steering stem moves freely from left to right with own weight. If play or stiffness is noticeable, re-adjust the steering stem nut.

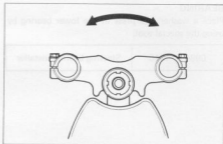
**HANDLEBARS**

- Install the handlebar mounting dampers to the steering stem bracket as shown in the figure.

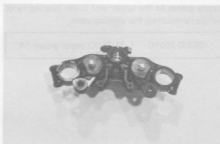

- Tighten the nuts ① to the specification and fit the cotter pins properly.

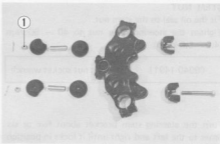

Tightening torque	40 – 60 N·m (4.0 – 6.0 kg·m)
-------------------	---------------------------------

- Set the handlebars to match its punched mark ② to the mating face of the holder.

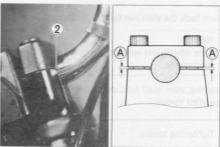

Secure the each handlebars clamp in such a way that the clearance A ahead of and behind the handlebars clamps are equalized.

Tightening torque	12 – 20 N·m (1.2 – 2.0 kg·m)
-------------------	---------------------------------

REAR WHEEL

CONSTRUCTION

SPOKE WHEEL

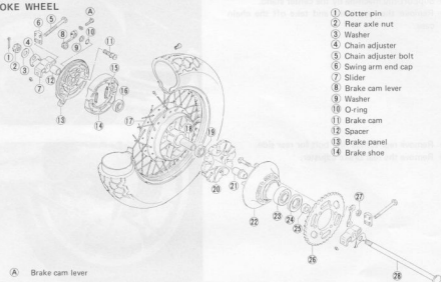

CAST WHEEL

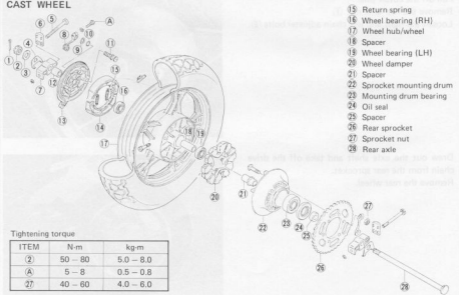

Tightening torque

ITEM	N·m	kg·m
2	50 - 80	5.0 - 8.0
A	5 - 8	0.5 - 0.8
27	40 - 60	4.0 - 6.0

REMOVAL AND DISASSEMBLY

- Support the machine by the center stand.
- Remove the two bolts and take off the chain case.



- Remove rear torque link bolt for rear side.
- Remove the rear brake adjuster.

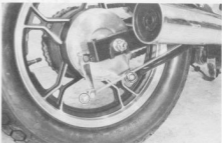

- Pull off the cotter pin.
- Remove the rear axle nut ①.
- Loosen the right and left chain adjuster bolts ②.



- Draw out the axle shaft and take off the drive chain from the rear sprocket.
- Remove the rear wheel.



- Draw out the rear sprocket mounting drum from the rear wheel.

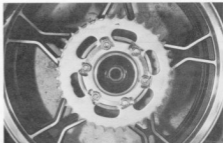

- Remove the six cushions.

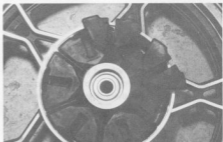
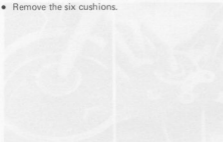

- Remove the right and left side wheel bearings.

NOTE:

Removing the left side bearing first makes the job easier.

CAUTION:

The removed bearing should be replaced.



- Flatten the washers and loosen the six nuts.

CAUTION:

Do not reuse the lock washers.

- Separate the rear sprocket from mounting drum.



- Remove the bearing by using the special tool.

09913-80112

Bearing remover

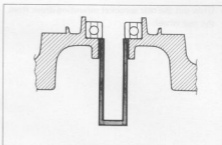

INSPECTION

REAR WHEEL AND MOUNTING DRUM BEARINGS

Inspect the play of bearing inner race by hand while fixing it in the wheel and mounting drum. Rotate the inner race by hand to inspect whether abnormal noise occurs or rotating smoothly. Replace the bearing if there is something unusual.

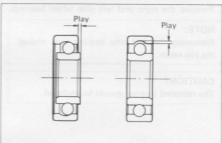

AXLE SHAFT

Using a dial gauge, check the axle shaft for run-out and replace it if the runout exceeds the limit.

09900-20606

Dial gauge (1/100)

Service Limit

0.25 mm

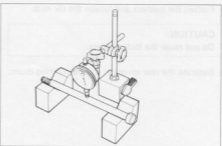

WHEEL

Make sure that the wheel runout checked as shown, does not exceed the service limit. An excessive runout is usually due to worn or loose wheel bearings, loose spokes or bent rim, and tightening

If bearing replacement or tightening spokes fails to reduce the runout, replace the wheel/rim.

NOTE:

Worn or loose wheel bearings must be replaced before attempting to true a wheel rim.

Service Limit (Axial and Radial)	2.0 mm
-------------------------------------	--------

SPOKE NIPPLE

Check to be sure that all nipples are tight, and retighten them as necessary using the special tool.

09940-60113	Spoke nipple wrench
-------------	---------------------

Tightening torque	4 – 5 N·m (0.4 – 0.5 kg·m)
-------------------	-------------------------------

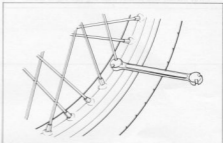
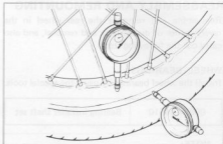
**CUSHION**

Inspect the cushions for wear and damage.

**SPROCKET**

Inspect the sprocket teeth for wear. If they are worn as illustrated, replace the sprocket and drive chain.

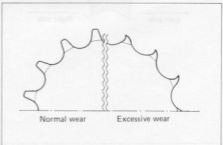

REASSEMBLY AND REMOUNTING

Reassemble and remount the rear wheel in the reverse order of disassembly and removal, and also carry out the following steps:

WHEEL BEARINGS

Install the wheel bearings by using the special tools.

09924-84510	Bearing installer shaft set
-------------	-----------------------------

NOTE:

First install the wheel bearing for right side.

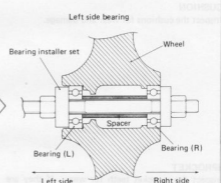
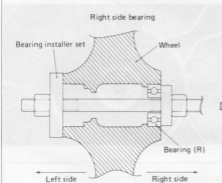
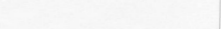
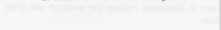
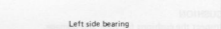
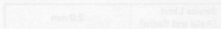

MOUNTING DRUM BEARING

Install the bearing by using the special tool.

09913-75520

Bearing installer

NOTE:

Apply grease to the bearings and oil seal lips before assembling rear wheel.

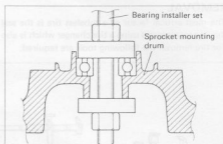
**REAR SPROCKET**

After tightening the six nuts to specification, bend the washers to lock nuts.

Tightening torque

40 – 60 N·m
(4.0 – 6.0 kg·m)

**REAR WHEEL ASSEMBLY**

Remount the rear wheel assembly as shown in the illustration.

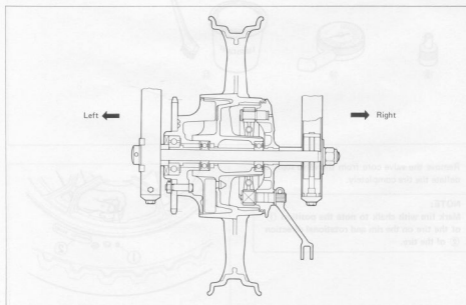

TIRE AND WHEEL (Only for cast wheel)**REMOVAL**

The most critical factor of a tubeless tire is the seal between the wheel rim and the tire bead. Because of this, we recommend using a tire changer which is also more efficient than tire levers.

For tire removal the following tools are required.

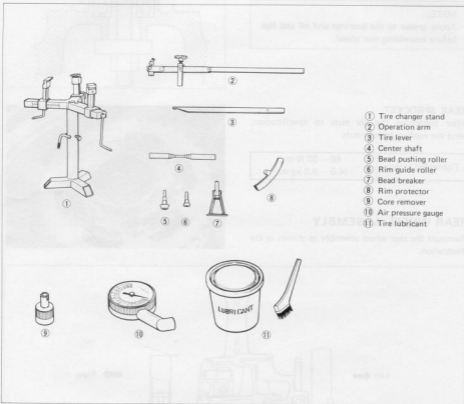

- Remove the valve core from the valve stem, and deflate the tire completely.

NOTE:

Mark tire with chalk to note the position ① of the tire on the rim and rotational direction ② of the tire.

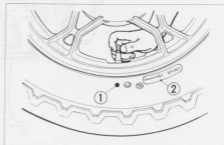

- Place the center shaft ① to the wheel, and fix the wheel firm by the rim holder ②.

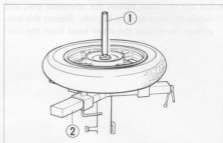

- Attach the operation arm ③ to the center shaft.

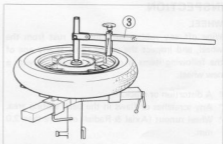

- Attach the bead breaker ④ to the operation arm, and dismount the bead from the rim. Turn the wheel over and dismount the other bead from the rim.

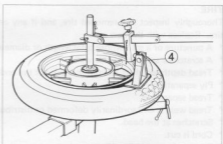

- Install the rim guide roller ⑤.
- Install the rim protector ⑥, and raise the tire bead with the tire lever ⑦.

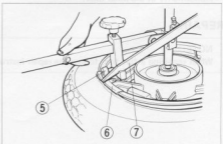

- Set the tire lever against the operation arm, and rotate the lever around the rim. Repeat this procedure to remove the other bead from the rim.

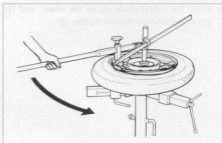

INSPECTION

WHEEL

Wipe off any rubber substance or rust from the wheel, and inspect the wheel rim. If any one of the following items is observed, replace it with a new wheel.

- * A distortion or crack.
- * Any scratches or flaws in the bead seating area.
- * Wheel runout (Axial & Radial) of more than 2.0 mm.

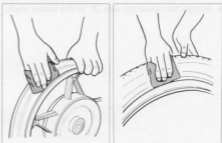

TIRE

Thoroughly inspect the removed tire, and if any one of the following items is observed, do not repair the tire. Replace with the new one.

- * A puncture or a split whose total length or diameter exceeds 6 mm.
- * A scratch or split at the side wall.
- * Tread depth less than 1.6 mm in the front tire and less than 2.0 mm in the rear tire.
- * Ply separation.
- * Tread separation.
- * Tread wear is extraordinarily deformed or distributed around the tire.
- * Scratches at the bead.
- * Cord is cut.
- * Damage from skidding (flat spots).
- * Abnormality in the inner liner.

REPAIR

NOTE:

When repairing a flat tire, follow the repair instructions and use only recommended repairing materials.

VALVE

INSPECTION

Inspect the valve after the tire is removed from the rim, and replace with the new valve if the seal rubber has any split or scratch.



Inspect the removed valve core and replace with the new one if seal rubber is abnormally deformed or worn.

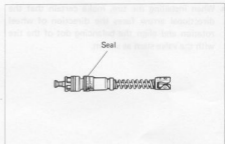
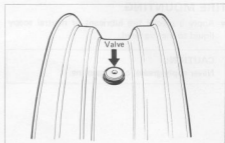

INSTALLATION

Any dust or rust around the valve hole must be cleaned off. Then install the valve in the rim.

CAUTION:

When installing the valve, tighten the nut ① by hand as much as possible. Holding the nut under this condition, tighten the lock nut ②. Do not overtighten nut ① as this may distort the rubber packing and cause an air leak.

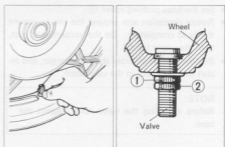
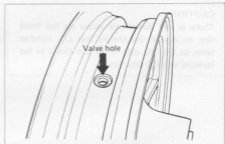

TIRE MOUNTING

- Apply a special tire lubricant or neutral soapy liquid to the tire bead.

CAUTION:

Never apply grease, oil or gasoline.



- When installing the tire, make certain that the directional arrow faces the direction of wheel rotation and align the balancing dot of the tire with the valve stem as shown.

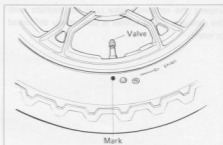

CAUTION:

There is not directional arrow on the front tire, so mount the tire so that I.D. number faces to the left side when the tire is in the forward running direction.

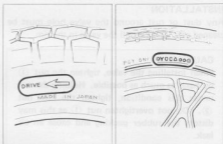

- Set the bead pushing roller ①.
- Rotate operation arm around the rim to mount the bead completely. Do the bottom bead first, then the upper bead.
- Remove the wheel from the tire changer, and install the valve core in the valve stem.

NOTE:

Before installing the valve core, inspect the core.

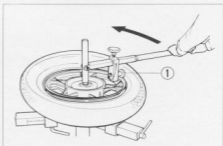

- Bounce the tire several times while rotating. This makes the tire bead expand outwards, and thus makes inflation easier.

NOTE:

Before inflating, confirm that the balance mark lines up with the valve stem.

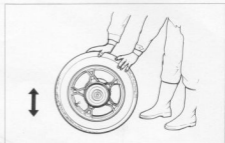

- Pump up the tire with air.

WARNING:

Do not inflate the tire to more than 4.0 kg/cm² (56 psi). The tire could burst with sufficient force to cause severe injury. Never stand directly over the tire while inflating it.

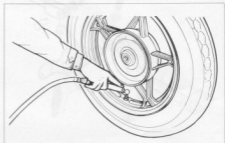
**NOTE:**

Check the "rim line" cast on the tire side walls. It must be equidistant from the wheel rim all the way around. If the distance between the rim line and the wheel rim varies, this indicates that the bead is not properly seated. If this is so, deflate the tire completely, and unseat the bead for the both sides. Coat the bead with lubricant, and try again.

mm	in	MPa
0.1 - 0.2	0.1 - 0.2	(0)
0.2 - 0.3	0.2 - 0.3	0.1

- After tire is properly seated to the wheel rim, adjust the pressure to the recommended pressure. Correct the wheel balance if necessary.

WARNING:

Do not run a repaired tire more than 50 km/h (30 mph) within 24 hours after tire repairing, since the patch may not be completely cured. Do not exceed 130 km/h (80 mph) with a repaired tire.

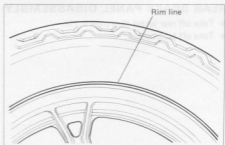

REAR BRAKE

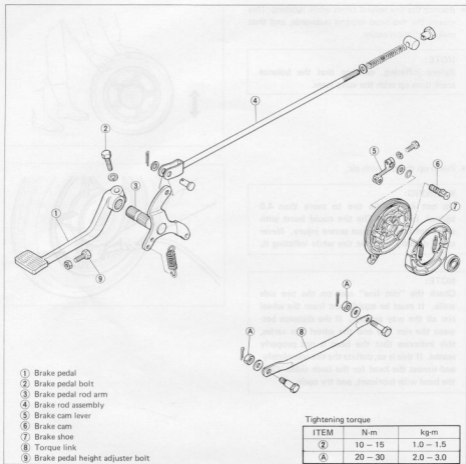

REAR BRAKE PANEL DISASSEMBLY

- Take off rear wheel (See page 6-25).
- Take off brake shoes.



- Remove fitting bolt and pull off brake cam lever.

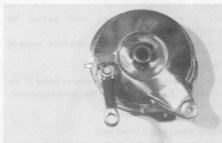

- Pull off brake cam, washer and O-ring.



INSPECTION

BRAKE DRUM

Measure the brake drum I.D. to determine the extent of wear and, if the limit is exceeded by the wear noted, replace the drum. The value of this limit is indicated inside the drum.

Service Limit	160.7 mm
---------------	----------



BRAKE SHOE

Check the brake shoes and decide whether they should be replaced or not by measuring the thickness of the brake shoe linings.

Service Limit	1.5 mm
---------------	--------

CAUTION:

Replace the brake shoes as a set, otherwise braking performance will be adversely affected.

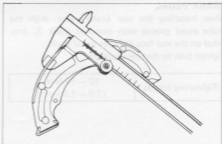

PANEL BUSHING

Inspect the panel bushing inner surface, for scratches and damage.

Replace the panel if there is anything unusual.

REASSEMBLY

Reassemble the brakes, in the reverse order of disassembly. Pay attention to the following points.

BRAKE CAM

Apply grease to the brake cam.

99000-25010	SUZUKI super grease "A"
-------------	-------------------------

WARNING:

Be careful not to apply too much grease to the brake cam shafts. If grease gets on the linings, brake slippage will result.

- Install the brake shoes and cam lever as shown in the illustration.

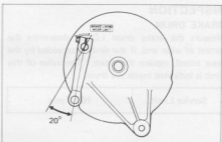
**BRAKE PEDAL**

When installing the rear brake pedal, align the brake pedal groove with punched mark ① provided on the end face of brake pedal shaft.

Tighten bolt to the specification.

Tightening torque	10 – 15 N·m (1.0 – 1.5 kg·m)
-------------------	---------------------------------

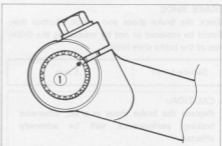

REAR SWING ARM AND SUSPENSION

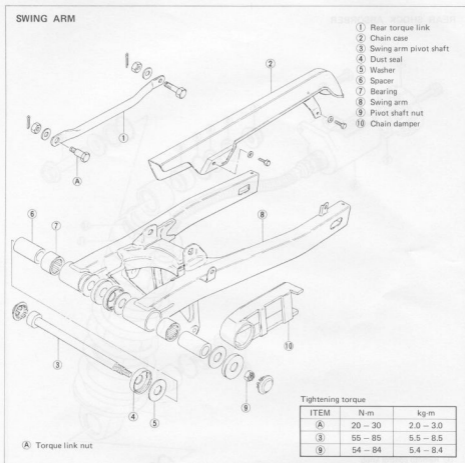

REMOVAL AND DISASSEMBLY

- Remove the following items to remove the rear swing arm and related parts.

- * Seat
- * Both frame covers
- * Ignitor and electrical parts holder
- * Battery, battery holder and tool case



REAR SHOCK ABSORBER

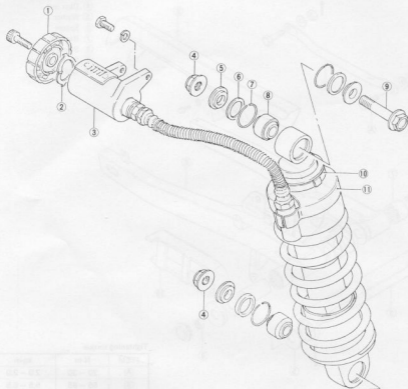

- ① Remote control knob
- ② Positioning washer
- ③ Rear shock absorber assembly
- ④ Rear shock absorber mounting nut
- ⑤ Washer
- ⑥ Oil seal
- ⑦ Circlip
- ⑧ Damper
- ⑨ Mounting bolt
- ⑩ Dust seal
- ⑪ Holder

Tightening torque

ITEM	N-m	kg-m
④	48 - 72	4.8 - 7.2

CUSHION ROD, LEVER AND BRACKET

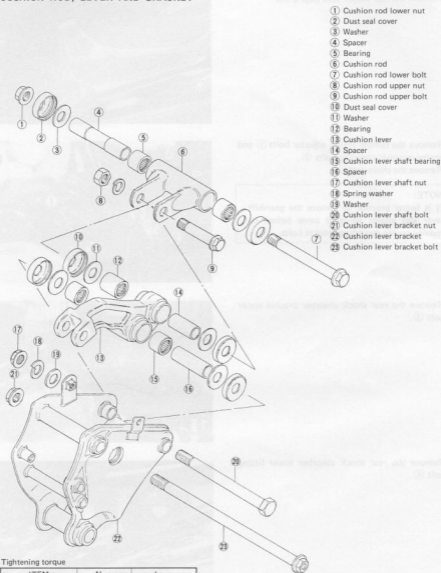

- ① Cushion rod lower nut
- ② Dust seal cover
- ③ Washer
- ④ Spacer
- ⑤ Bearing
- ⑥ Cushion rod
- ⑦ Cushion rod lower bolt
- ⑧ Cushion rod upper nut
- ⑨ Cushion rod upper bolt
- ⑩ Dust seal cover
- ⑪ Washer
- ⑫ Bearing
- ⑬ Cushion lever
- ⑭ Spacer
- ⑮ Cushion lever shaft bearing
- ⑯ Spacer
- ⑰ Cushion lever shaft nut
- ⑱ Spring washer
- ⑲ Washer
- ⑳ Cushion lever shaft bolt
- ㉑ Cushion lever bracket nut
- ㉒ Cushion lever bracket
- ㉓ Cushion lever bracket bolt

Tightening torque

ITEM	N·m	kg·m
①, ⑧, ⑰, ㉑	70 - 100	7.0 - 10.0

- Remove the right and left muffler brackets.
- Remove the rear wheel. (See page 6-25)



- Remove the remote spring adjuster bolts ① and engine mounting bracket bolts ②.
- Remove the chain case.

NOTE:

It is better practice to remove the gearshift lever and engine sprocket cover before removing engine mounting bracket bolts.

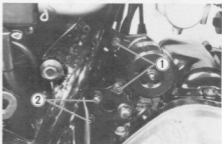

- Remove the rear shock absorber bracket upper bolt ③.



- Remove the rear shock absorber lower fitting bolt ④.

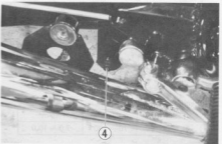

- Remove the rear swing arm pivot nut by holding the pivot shaft with 14 mm hexagon wrench.
- Remove the swing arm pivot shaft with 14 mm hexagon wrench.

09900-18720

14 mm hexagon wrench

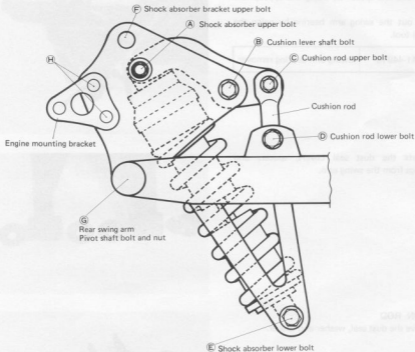

Tightening torque

ITEM	N-m	kg-m
(A), (E)	48 - 72	4.8 - 7.2
(B), (C), (D), (F)	70 - 100	7.0 - 10.0
(G)	bolt	55 - 85
	nut	54 - 84
(H)	20 - 30	2.0 - 3.0

REAR SWING ARM

- Remove the chain defense buffer and dust seal covers.

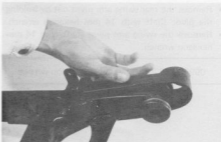

- Draw out the spacer by using the appropriate drift.
- Draw out the swing arm bearing by using the special tool.

09941-44910

Swing arm bearing remover

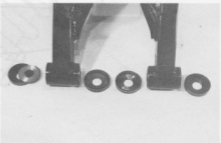

- Separate the dust seal covers, spacers and bearings from the swing arm.

**CUSHION ROD**

- Remove the dust seal, washer and spacer.

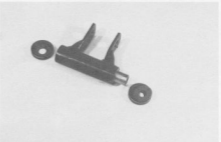

Model	Part No.	Qty.
01-02	21-02	2
03-04	021-02	2
05-06	02-02	2
07-08	03-02	2
09-10	04-02	2
11-12	05-02	2

- Remove the bearing by using the special tools.

09923-74510	Bearing puller
09930-30102	Rotor remover slide shaft

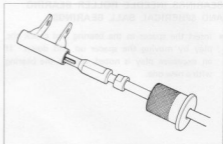

CUSHION LEVER

- Remove the dust seal, washer and spacer.



- Remove the bearing by using the special tools.

09923-74510	Bearing puller
09930-30102	Rotor remover slide shaft

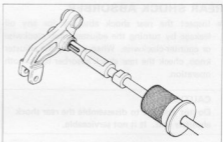

INSPECTION

SWING ARM PIVOT SHAFT

Using a dial gauge, check the pivot shaft for runout and replace it if the runout exceeds the limit.

09900-20606	Dial gauge (1/100)
-------------	--------------------

Service Limit	0.3 mm
---------------	--------

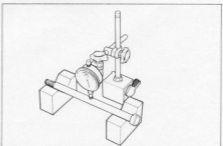

BEARINGS (NEEDLE ROLLER BEARING AND SPHERICAL BALL BEARINGS).

- Insert the spacer in the bearing and check the play by moving the spacer up and down. If an excessive play is noted, replace the bearing with a new one.

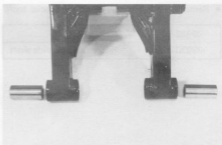

- Spherical ball bearings are located on upper and lower shock absorber. Insert the mounting bolt to the bearing and check the play by moving the bolt. If an excessive play is noted, replace the bearing with a new one.

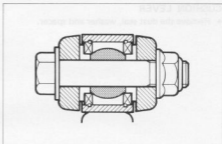

REAR SHOCK ABSORBER

- Inspect the rear shock absorber for any oil leakage by turning the adjuster knob clockwise or counter-clockwise. When turning the adjuster knob, check the rear shock absorber for smooth operation.

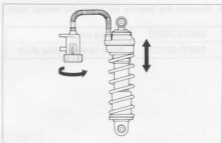

CAUTION:

Do not attempt to disassemble the rear shock absorber unit. It is not serviceable.



INSPECTION

SWING ARM PIVOT SHAFT

Using a dial gauge, check the pivot shaft for wear.

and replace it if the amount exceeds the limit.

Oil Gauge (1/100)	0.000-0.005
Dial Gauge	Service Limit

REASSEMBLY

Reassemble and remount the swing arm in the reverse order of disassembly and removal, and also carry out the following steps:

SWING ARM BEARINGS

Force-fit the bearings into the swing arm by using the special tool.

09941-34513	Swing arm bearing installer set
-------------	---------------------------------

NOTE:

When installing two bearings, punch-marked side of bearing comes outside.

SPACER AND DUST SEAL COVER

Apply grease to the spacer and dust seal cover when installing them.

99000-25010	SUZUKI Super grease "A"
-------------	-------------------------

CUSHION ROD BEARINGS AND LEVER BEARINGS

Install the right and left bearings by using the special tool.

09941-34513	Bearing installer set
-------------	-----------------------

NOTE:

When installing the two bearings, punch-marked side of bearing faces outwards.

- Apply grease to the spacer and bearings.

99000-25010	SUZUKI Super grease "A"
-------------	-------------------------

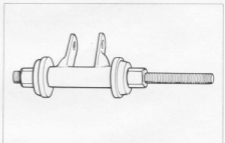
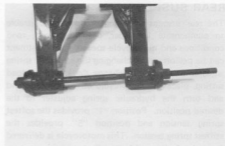

REAR SUSPENSION

The rear suspension spring pre-load is adjustable to compensate for rider, passenger, load, road conditions and motorcycle speed. The adjustment can be performed by changing the hydraulic spring adjuster position. To change the spring pre-load setting, place the motorcycle on the center stand and turn the hydraulic spring adjuster to the desired position. Position "1" provides the softest spring tension and position "5" provides the stiffest spring tension. This motorcycle is delivered from the factory with its adjuster position set on the "1" position.

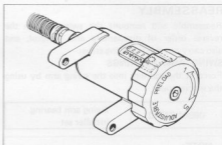

FINAL INSPECTION AND ADJUSTMENT

After installing rear swing arm, shock absorber, brake and rear wheel, following adjustments are required before driving motorcycle.

- * Drive chain 2-13
- * Rear brake 2-18
- * Tire pressure 2-19
- * Chassis bolts and nuts 2-21

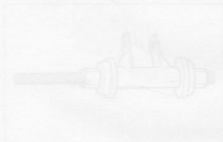

SERVICING INFORMATION

CONTENTS

TROUBLESHOOTING	7- 1
WIRING DIAGRAM	7- 9
WIRE ROUTING	7-16
CABLE ROUTING	7-18
SPECIAL TOOLS	7-22
TIGHTENING TORQUE	7-29
SERVICE DATA	7-32

TROUBLESHOOTING

ENGINE

Complaint	Symptom and possible causes	Remedy
Engine will not start, or is hard to start.	<p>Compression too low</p> <ol style="list-style-type: none"> 1. Tappet clearance out of adjustment. 2. Worn valve guides or poor seating of valves. 3. Valves mistiming. 4. Piston rings excessively worn. 5. Worn-down cylinder bores. 6. Starter motor cranks but too slowly. <p>Plugs not sparking</p> <ol style="list-style-type: none"> 1. Damaged spark plugs. 2. Wet spark plugs. 3. Defective ignition coil. 4. Open or short in high-tension cords. 5. Defective transistor unit or signal generator. <p>No fuel reaching the carburetors</p> <ol style="list-style-type: none"> 1. Clogged hole in the fuel tank cap. 2. Clogged or defective fuel cock. 3. Defective carburetor float valve. 4. Clogged fuel pipe of defective vacuum pipe. 	<p>Adjust. Repair, or replace. Adjust. Replace. Replace, or rebore. Consult "electrical complaints".</p> <p>Replace. Clean and dry. Replace. Replace. Replace.</p> <p>Clean. Clean or replace. Replace. Clean or replace.</p>
Engine stalls easily.	<ol style="list-style-type: none"> 1. Carbon deposited on the spark plugs. 2. Defective ignition coil, signal generator. 3. Clogged fuel pipe. 4. Clogged jets in carburetors. 5. Tappet clearance out of adjustment. 	<p>Clean. Replace. Clean. Clean. Adjust.</p>
Noisy engine.	<p>Excessive tappet chatter</p> <ol style="list-style-type: none"> 1. Tappet clearance too large. 2. Weakened or broken valve springs. 3. Camshaft journal worn and burnt. <p>Noise appears to come from pistons</p> <ol style="list-style-type: none"> 1. Pistons or cylinders worn down. 2. Combustion chambers fouled with carbon. 3. Piston pin or piston pin bore worn. 4. Piston rings or ring grooves worn. <p>Noise seems to come from timing chain</p> <ol style="list-style-type: none"> 1. Stretched chain. 2. Worn sprockets. 3. Tension adjuster not working. <p>Noise seems to come from clutch</p> <ol style="list-style-type: none"> 1. Worn splines of countershaft or hub. 2. Worn teeth of clutch plates. 3. Distorted clutch plates, driven and drive. 4. Weaken clutch spring. 	<p>Adjust. Replace. Replace.</p> <p>Replace. Clean. Replace. Replace.</p> <p>Replace. Replace. Repair or replace.</p> <p>Replace. Replace. Repair or replace. Replace.</p>

Complaint	Symptom and possible causes	Remedy
Noisy engine	Noise seems to come from crankshaft 1. Worn or burnt journal or counterbalancer bearings. 2. Worn or burnt conrod big-end bearings. 3. Thrust clearance too large. 4. Worn counter balancer drive and driven gear.	Replace. Replace. Replace. Replace.
	Noise seems to come from transmission 1. Gears worn or rubbing. 2. Badly worn splines. 3. Primary gears worn or rubbing. 4. Counter balancer gear worn or rubbing. 5. Worn or damaged bearings of drive shaft, countershaft.	Replace. Replace. Replace. Replace. Replace.
Slipping clutch	1. Clutch control out of adjustment or loss of play. 2. Weakened clutch springs. 3. Worn or distorted pressure plate. 4. Distorted clutch plates, driven and drive.	Adjust. Replace. Replace. Replace.
Dragging clutch	1. Clutch control out of adjustment or too much play. 2. Some clutch springs weakened while others are not. 3. Distorted pressure plate or clutch plates.	Adjust. Replace. Replace.
Transmission will not shift.	1. Broken gearshift cam or bearing. 2. Distorted or worn gearshift forks.	Replace. Replace.
Transmission will not shift back.	1. Broken return spring on shift shaft. 2. Shift shafts are rubbing or sticky. 3. Distorted or worn gearshift fork.	Replace. Repair. Replace.
Transmission jumps out of gear.	1. Worn shifting gears on countershaft or driveshaft. 2. Distorted or worn gearshift forks. 3. Weakened stopper spring on gearshift stopper.	Replace. Replace. Replace.
Engine idles poorly.	1. Tappet clearance out of adjustment. 2. Poor seating of valves. 3. Defective valve guides. 4. Spark plug gaps too wide. 5. Defective ignition coil. 6. Defective signal generator or ignitor. 7. Float-chamber fuel level out of adjustment in carburetors. 8. Clogged jets or imbalance of carburetors.	Adjust. Replace. Replace. Adjust or replace. Replace. Replace. Adjust. Clean or adjust.
Engine runs poorly in high-speed range.	1. Valve spring weakened. 2. Valve timing out of adjustment. 3. Spark plug gaps too narrow. 4. Ignition not advanced sufficiently due to poorly working ignitor. 5. Defective ignition coil. 6. Defective signal generator or ignitor. 7. Float-chamber fuel level too low. 8. Clogged air cleaner element. 9. Clogged fuel pipe, resulting in inadequate fuel supply to carburetors. 10. Clogged fuel cock vacuum pipe.	Replace. Adjust. Adjust. Replace. Replace. Replace. Adjust. Clean. Clean, and prime. Clean.

Complaint	Symptom and possible causes	Remedy
Dirty or heavy exhaust smoke.	<ol style="list-style-type: none"> 1. Too much engine oil in the engine. 2. Worn piston rings or cylinders. 3. Worn valve guides. 4. Cylinder walls scored or scuffed. 5. Worn valve stems. 6. Defective stem seal. 	<p>Check with level gauge drain out excess oil.</p> <p>Replace.</p> <p>Replace.</p> <p>Rebore or replace.</p> <p>Replace.</p> <p>Replace.</p>
Engine lacks power	<ol style="list-style-type: none"> 1. Loss of tappet clearance. 2. Weakened valve springs. 3. Valve timing out of adjustment. 4. Worn piston rings or cylinders. 5. Poor seating of valves. 6. Spark plug gaps incorrect. 7. Clogged jets in carburetors. 8. Float-chamber fuel level out of adjustment. 9. Clogged air cleaner element. 10. Carburetor balancing screw loose. 11. Too much engine oil in the engine. 12. Fouled spark plug. 13. Sucking air from intake pipe. 	<p>Adjust.</p> <p>Replace.</p> <p>Adjust.</p> <p>Replace.</p> <p>Repair.</p> <p>Adjust or replace.</p> <p>Clean.</p> <p>Adjust.</p> <p>Clean.</p> <p>Retighten.</p> <p>Drain out excess oil.</p> <p>Clean or replace.</p> <p>Retighten or replace.</p>
Engine overheats.	<ol style="list-style-type: none"> 1. Heavy carbon deposit on piston crowns. 2. Not enough oil in the engine. 3. Defective oil pump or clogged oil circuit. 4. Fuel level too low in float chambers. 5. Air leakage from intake pipe. 6. Use of incorrect engine oil. 7. Use of improper spark plug. 	<p>Clean.</p> <p>Add oil.</p> <p>Replace or clean.</p> <p>Adjust.</p> <p>Retighten or replace.</p> <p>Change.</p> <p>Change.</p>

CARBURETOR

Complaint	Symptom and possible causes	Remedy
Trouble with starting	<ol style="list-style-type: none"> 1. Starter jet is clogged. 2. Starter pipe is clogged. 3. Air leaking from a joint between starter body and carburetor. 4. Air leaking from carburetor's joint or vacuum gauge joint. 5. Starter plunger is not operating properly. 	<p>Clean. Clean.</p> <p>Check starter body and carburetor for tightness, adjust and replace gasket.</p> <p>Check and adjust.</p> <p>Check and adjust.</p>
Idling or low-speed trouble	<ol style="list-style-type: none"> 1. Pilot jet, pilot air jet are clogged or loose. 2. Air leaking from carburetor's joint, vacuum gauge joint, or starter. 3. Pilot outlet or bypass is clogged. 4. Starter plunger is not fully closed. 	<p>Check and clean. Check and adjust.</p> <p>Check and clean. Check and adjust.</p>
Medium- or high-speed trouble	<ol style="list-style-type: none"> 1. Main jet or main air jet is clogged. 2. Needle jet is clogged. 3. Fuel leaking due to a broken O-ring in needle jet. 4. Throttle valve is not operating properly. 5. Fuel filter is clogged. 	<p>Check and clean. Check and clean.</p> <p>Replace O-ring. Check throttle valve for operation.</p> <p>Check and clean.</p>
Overflow and fuel level fluctuations	<ol style="list-style-type: none"> 1. Needle valve is worn or damaged. 2. Spring in needle valve is broken. 3. Float is not working properly. 4. Foreign matter has adhered to needle valve. 5. Fuel level is too high or low. 	<p>Replace. Replace.</p> <p>Check and adjust.</p> <p>Clean. Adjust float height.</p>

ELECTRICAL

Complaint	Symptom and possible causes	Remedy
No sparking or poor sparking	<ol style="list-style-type: none"> 1. Defective ignition coil. 2. Defective spark plugs. 3. Defective signal generator or ignitor. 4. Loose connection of lead wire. 	<p>Replace. Replace.</p> <p>Replace. Connect/tighten.</p>
Spark plugs soon become fouled with carbon.	<ol style="list-style-type: none"> 1. Mixture too rich. 2. Idling speed set too high. 3. Incorrect gasoline. 4. Dirty element in air cleaner. 5. Spark plugs too cold. 	<p>Adjust carburetors. Adjust carburetors.</p> <p>Change. Clean.</p> <p>Replace by hot type plugs.</p>
Spark plugs become fouled too soon.	<ol style="list-style-type: none"> 1. Worn piston rings. 2. Pistons or cylinders worn. 3. Excessive clearance of valve stems in valve guides. 4. Worn stem oil seal. 	<p>Replace. Replace.</p> <p>Replace. Replace.</p>

Complaint	Symptom and possible causes	Remedy
Spark plug electrodes overheat or burn.	<ol style="list-style-type: none"> 1. Spark plugs too hot. 2. The engine overheats. 3. Spark plugs loose. 4. Mixture too lean. 	Replace by cold type plugs. Tune up. Retighten. Adjust carburetors.
Generator does not charge.	<ol style="list-style-type: none"> 1. Open or short in lead wires, or loose lead connections. 2. Shorted, grounded or open generator coil. 3. Shorted or open regulator/rectifier. 	Repair or replace or retighten. Replace. Replace.
Generator does charge, but charging rate is below the specification.	<ol style="list-style-type: none"> 1. Lead wires tend to get shorted or open-circuited or loosely connected at terminals. 2. Grounded or open-circuited stator coils of generator. 3. Defective regulator/rectifier. 4. Not enough electrolyte in the battery. 5. Defective cell plates in the battery. 	Repair, or retighten. Replace. Replace. Add distilled water to the upper level. Replace the battery.
Generator overcharges.	<ol style="list-style-type: none"> 1. Internal short-circuit in the battery. 2. Resistor element in the regulator/rectifier damaged or defective. 3. Regulator/rectifier poorly grounded. 	Replace the battery. Replace. Clean and tighten ground connection.
Unstable charging.	<ol style="list-style-type: none"> 1. Lead wire insulation frayed due to vibration, resulting in intermittent shorting. 2. Generator internally shorted. 3. Defective regulator/rectifier. 	Repair or replace. Replace. Replace.
Starter button is not effective.	<ol style="list-style-type: none"> 1. Battery run down. 2. Defective switch contacts. 3. Brushes not seating properly on commutator in starter motor. 4. Defective starter relay. 	Recharge or replace. Replace. Repair or replace. Replace.

BATTERY

Symptom	Possible causes	Remedy
"Sulfation", acidic white powdery substance or spots on surfaces of cell plates.	<ol style="list-style-type: none"> 1. Not enough electrolyte. 2. Battery case is cracked. 3. Battery has been left in a run-down condition for a long time. 4. Adulterated electrolyte (Foreign matter has entered the battery and become mixed with the electrolyte). 	<p>Add distilled water, if the battery has not been damaged and "sulfation" has not advanced too far, and recharge. Replace the battery. Replace the battery.</p> <p>If "sulfation" has not advanced too far, try to restore the battery by replacing the electrolyte, recharging it fully with the battery detached from the motorcycle and then adjusting electrolyte S.G.</p>
Battery runs down quickly.	<ol style="list-style-type: none"> 1. The charging method is not correct. 2. Cell plates have lost much of their active material as a result of over-charging. 3. A short-circuit condition exists within the battery due to excessive accumulation of sediments caused by the high electrolyte S.G. 4. Electrolyte S.G. is too low. 5. Adulterated electrolyte. 6. Battery is too old. 	<p>Check the generator, regulator/rectifier and circuit connections, and make necessary adjustments to obtain specified charging operation. Replace the battery, and correct the charging system. Replace the battery.</p> <p>Recharge the battery fully and adjust electrolyte S.G. Replace the electrolyte, recharge the battery and then adjust S.G. Replace the battery.</p>
Reversed battery polarity	The battery has been connected the wrong way round in the system, so that it is being charged in the reverse direction.	Replace the battery and be sure to connect the battery properly.
Battery "sulfation"	<ol style="list-style-type: none"> 1. Charging rate too low or too high. (When not in use batteries should be recharged at least once a month to avoid sulfation) 2. Battery electrolyte excessive or insufficient, or its specific gravity too high or too low. 3. The battery left unused for too long in cold climate. 	<p>Replace the battery.</p> <p>Keep the electrolyte up to the prescribed level, or adjust the S.G. by consulting the battery maker's directions. Replace the battery, if badly sulfated.</p>
Battery discharges too rapidly.	<ol style="list-style-type: none"> 1. Dirty container top and sides. 2. Impurities in the electrolyte or electrolyte S.G. is too high. 	<p>Clean. Change the electrolyte by consulting the battery maker's directions.</p>

CHASSIS

Complaint	Symptom and possible causes	Remedy
Handling feels too heavy.	<ol style="list-style-type: none"> 1. Steering stem nut overtightened. 2. Broken bearing/race in steering stem. 3. Distorted steering stem. 4. Not enough pressure in tires. 	Adjust. Replace. Replace. Adjust.
Wobbly handle	<ol style="list-style-type: none"> 1. Loss of balance between right and left suspension. 2. Distorted front fork. 3. Distorted front axle or crooked tire. 4. Incorrect front fork air pressure. 	Adjust or replace. Repair or replace. Replace. Adjust.
Wobbly front wheel	<ol style="list-style-type: none"> 1. Distorted wheel rim. 2. Worn front wheel bearings. 3. Loose wheel spokes. 4. Defective or incorrect tire. 5. Loose nut on axle. 6. Incorrect front fork oil, air pressure. 7. Loose nuts on the rear shock. 8. Worn swing arm related bearing/bushing. 	Replace. Replace. Retighten. Replace. Retighten. Adjust. Retighten. Replace.
Front suspension too soft	<ol style="list-style-type: none"> 1. Weakened springs. 2. Not enough fork oil. 	Replace. Refill.
Front suspension too stiff	<ol style="list-style-type: none"> 1. Fork oil too viscous. 2. Too much fork oil. 3. Incorrect air pressure in front suspension. 	Replace. Drain excess oil. Adjust.
Noisy front suspension	<ol style="list-style-type: none"> 1. Not enough fork oil. 2. Loose nuts on suspension. 	Refill. Retighten.
Wobbly rear wheel	<ol style="list-style-type: none"> 1. Distorted wheel rim. 2. Worn-down rear wheel bearings. 3. Loose wheel spokes. 4. Defective or incorrect tire. 5. Loose nuts on the rear shock. 6. Worn swing arm related bearing/bushing. 	Replace. Replace. Retighten. Replace. Replace. Replace.
Rear suspension too soft	<ol style="list-style-type: none"> 1. Weakened springs. 2. Rear suspension adjuster improperly set. 3. Oil leakage of rear shock. 	Replace. Adjust. Replace.
Rear suspension too stiff	<ol style="list-style-type: none"> 1. Rear suspension adjuster improperly set. 2. Worn swing arm related bearing/bushing. 	Adjust. Replace.
Noisy rear suspension	<ol style="list-style-type: none"> 1. Loose nuts on suspension system. 2. Worn swing arm related bearing/bushing. 	Retighten. Replace.
Poor braking (FRONT)	<ol style="list-style-type: none"> 1. Not enough brake fluid in the reservoir. 2. Air trapped in brake fluid circuit. 3. Pads or linings worn down. 	Refill to level mark. Bleed air out. Replace.

BRAKES

Complaint	Symptom and possible causes	Remedy
Insufficient brake power	<ol style="list-style-type: none"> 1. Leakage of brake fluid from hydraulic system. 2. Worn pads or shoe. 3. Oil adhesion on engaging surface of pads. 4. Worn disc. 5. Air in hydraulic system. 6. Too much brake pedal play. 	Repair or replace. Replace. Clean disc and pads. Replace. Bleed air. Adjust.
Brake squeaking	<ol style="list-style-type: none"> 1. Carbon adhesion on pad surface. 2. Tilted pad. 3. Damaged wheel bearing. 4. Loose front-wheel axle or rear-wheel axle. 5. Worn pads or shoe. 6. Foreign material in brake fluid. 7. Clogged return port of master cylinder. 	Repair surface with sandpaper. Modify pad fitting. Replace. Tighten to specified torque. Replace. Replace brake fluid. Disassemble and clean master cylinder.
Excessive brake lever stroke	<ol style="list-style-type: none"> 1. Air in hydraulic system. 2. Worn brake lever cam. 3. Insufficient brake fluid. 4. Improper quality of brake fluid. 	Bleed air. Replace brake lever. Replenish fluid to specified level; bleed air. Replace with correct fluid.
Leakage of brake fluid	<ol style="list-style-type: none"> 1. Insufficient tightening of connection joints. 2. Cracked hose. 3. Worn piston and/or cup. 	Tighten to specified torque. Replace. Replace piston and/or cup.

WIRING DIAGRAM

FOR GR650X (SPOKE WHEEL TYPE) E01, 06, 24

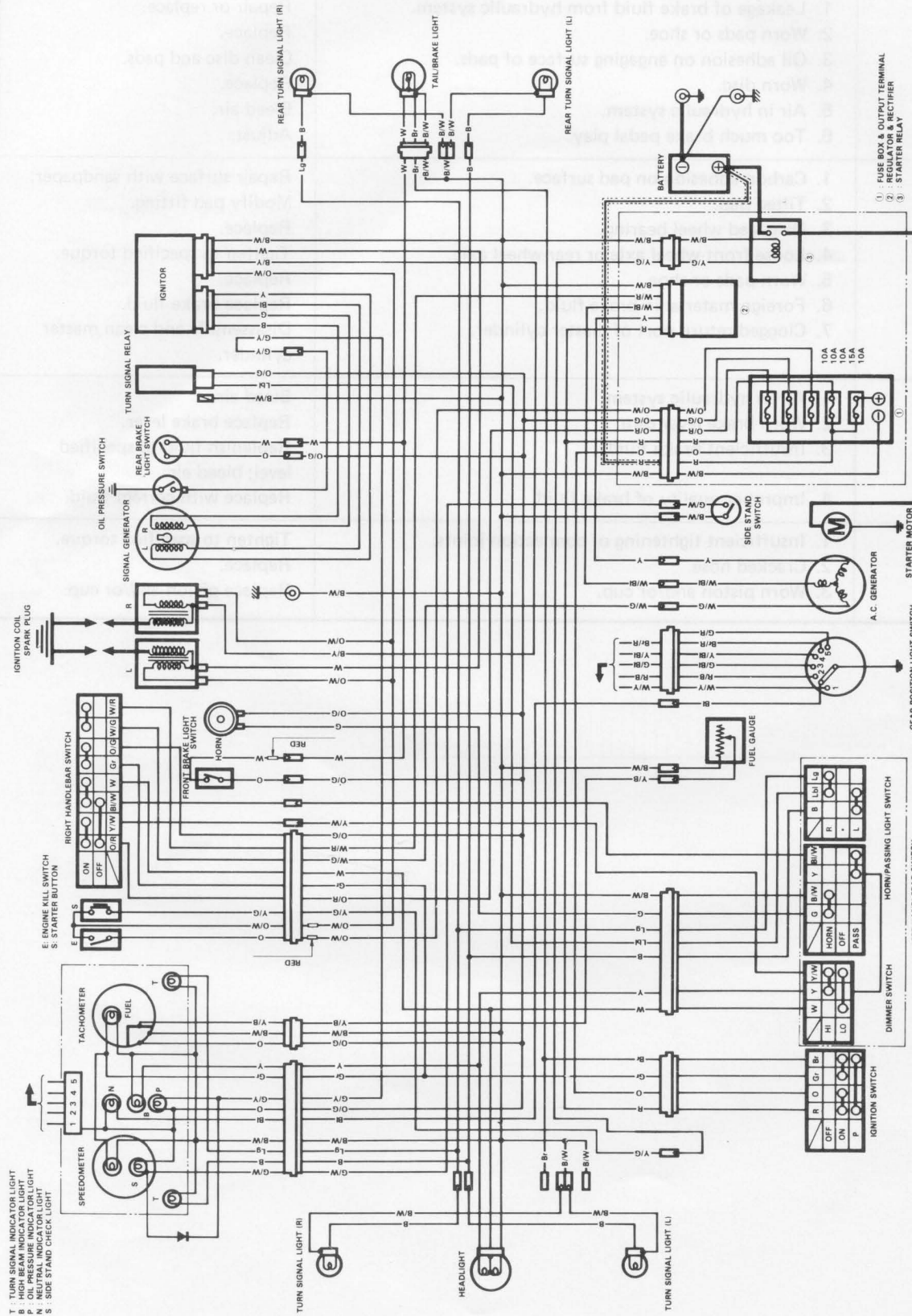

- ① : FUSE BOX & OUTPUT TERMINAL
 ② : REGULATOR & RECTIFIER
 ③ : STARTER RELAY
- W/Y White with Yellow tracer
 Y/B Yellow with Black tracer
 Y/Bl Yellow with Blue tracer
 Y/G Yellow with Green tracer
 Y/W Yellow with White tracer
- G/W Green with White tracer
 G/Y Green with Yellow tracer
 O/G Orange with Green tracer
 O/R Orange with Red tracer
 O/W Orange with White tracer
 R/B Red with Black tracer
 W/G White with Green tracer
 W/R White with Red tracer
- R Red
 W White
 Y Yellow
 B/W Black with White tracer
 B/Y Black with Yellow tracer
 Br/R Brown with Red tracer
 G/Bl Green with Blue tracer
 G/R Green with Red tracer
- B Black
 Bl Blue
 Br Brown
 G Green
 Gr Gray
 Lbl Light blue
 Lg Light green
 O Orange
- T TURN SIGNAL INDICATOR LIGHT
 B HIGH BEAM INDICATOR LIGHT
 P OIL PRESSURE INDICATOR LIGHT
 S SIDE STAND CHECKER LIGHT

FOR GR650 (CAST WHEEL TYPE) E-01, 02, 04, 06, 15, 17, 21, 24, 25, 39
 FOR GR650X (SPOKE WHEEL TYPE) E39

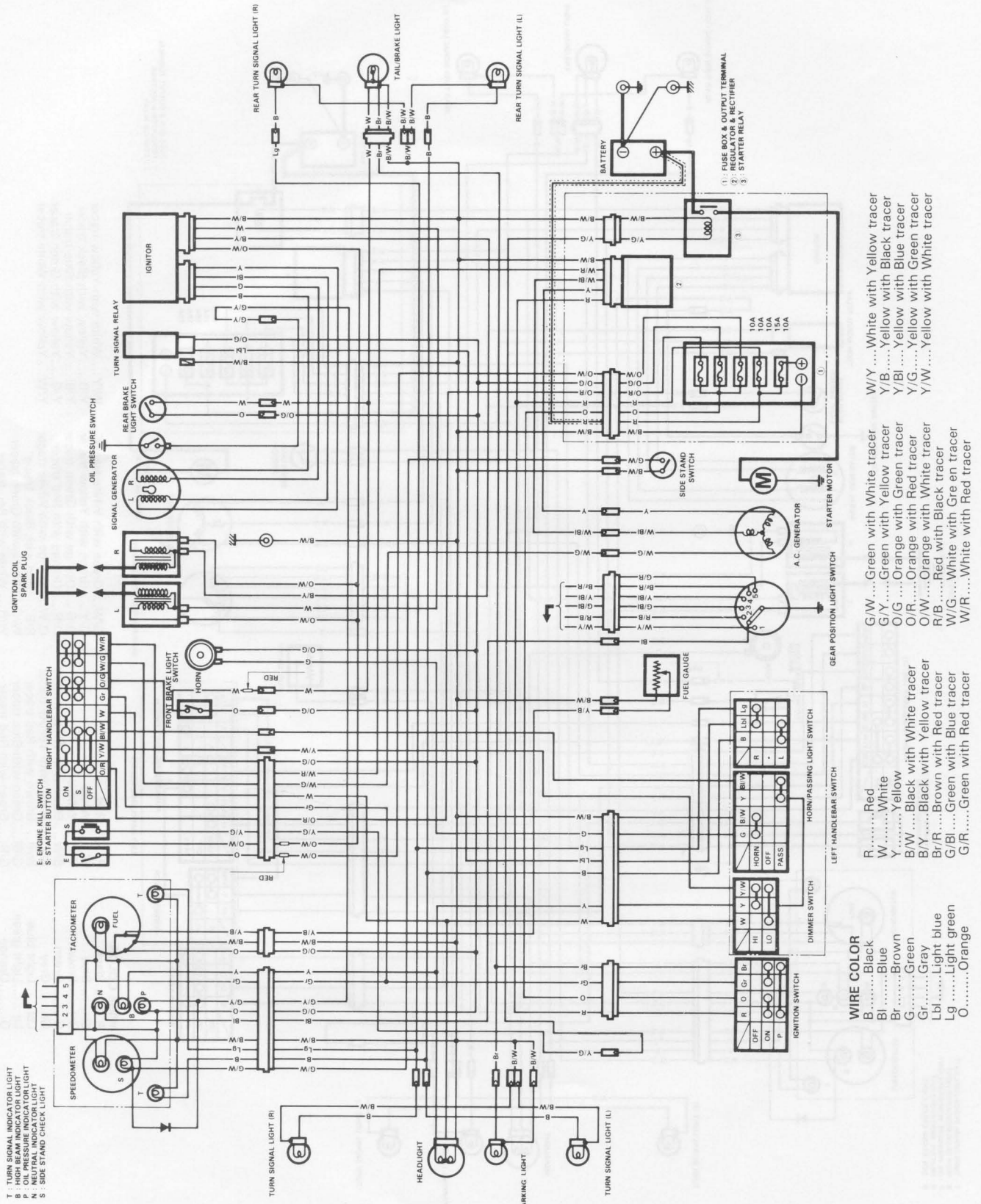

FOR GR650 & GR650X E28

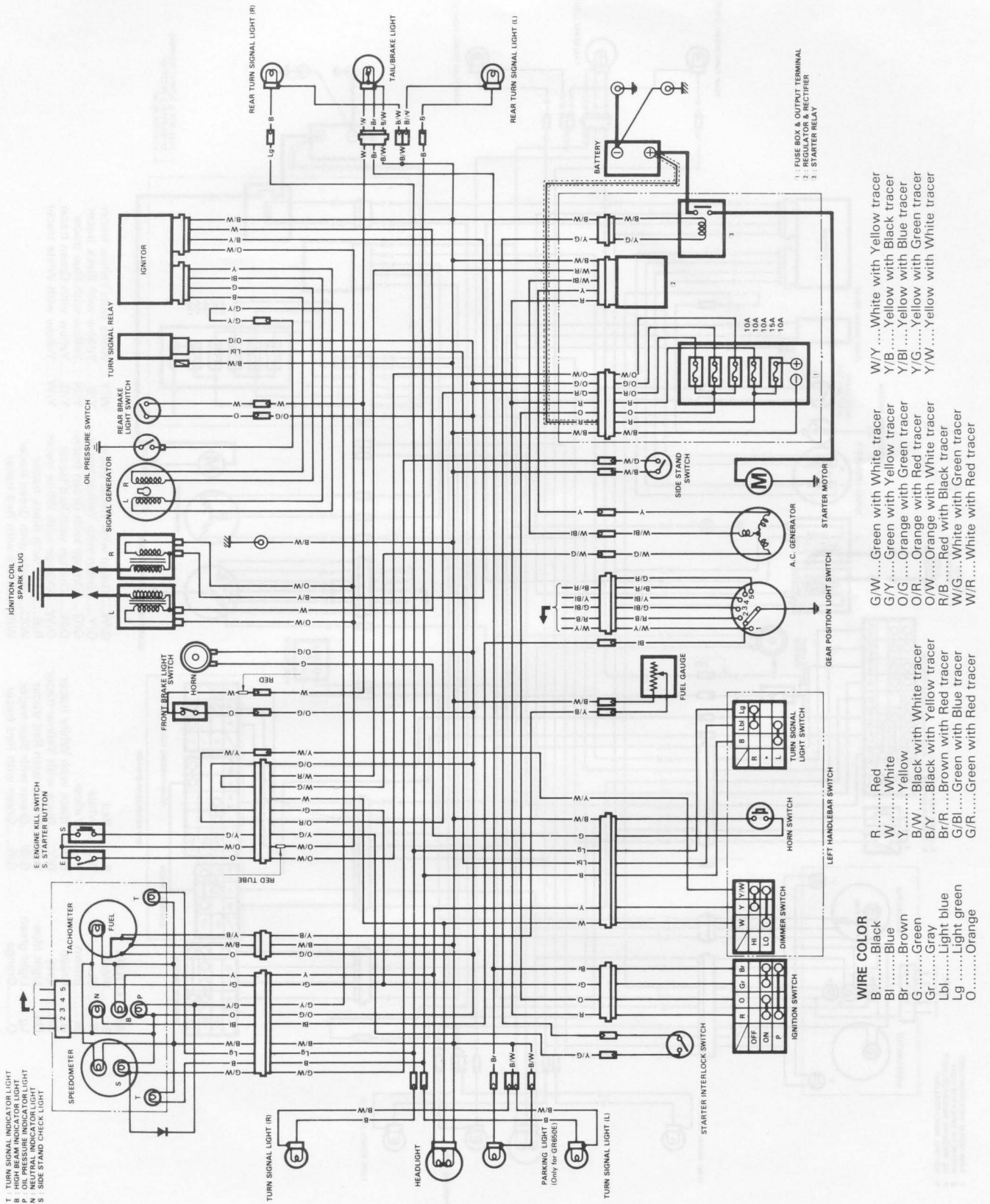

FOR GR650 E16, 18, 26

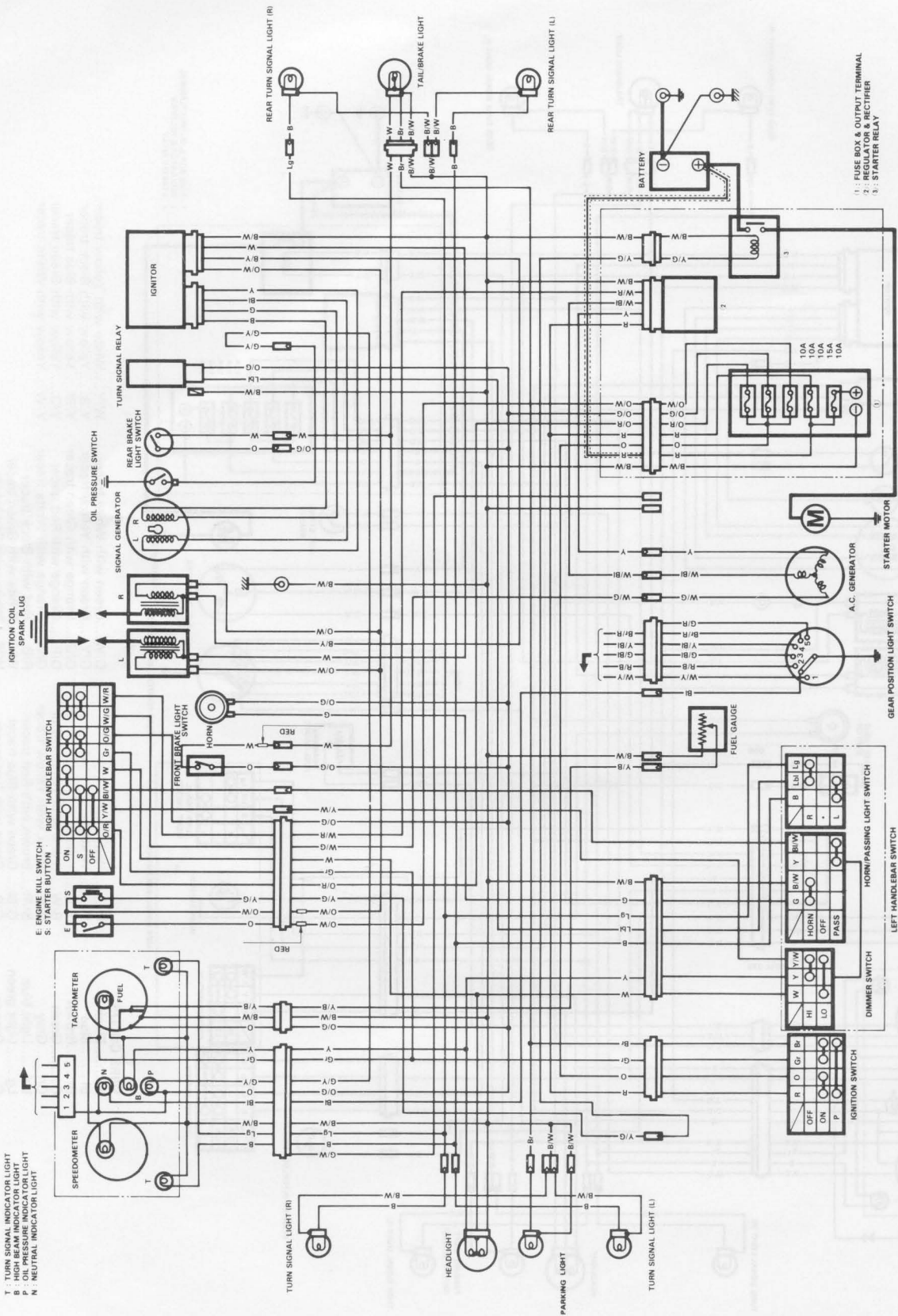

FOR GR650 E34

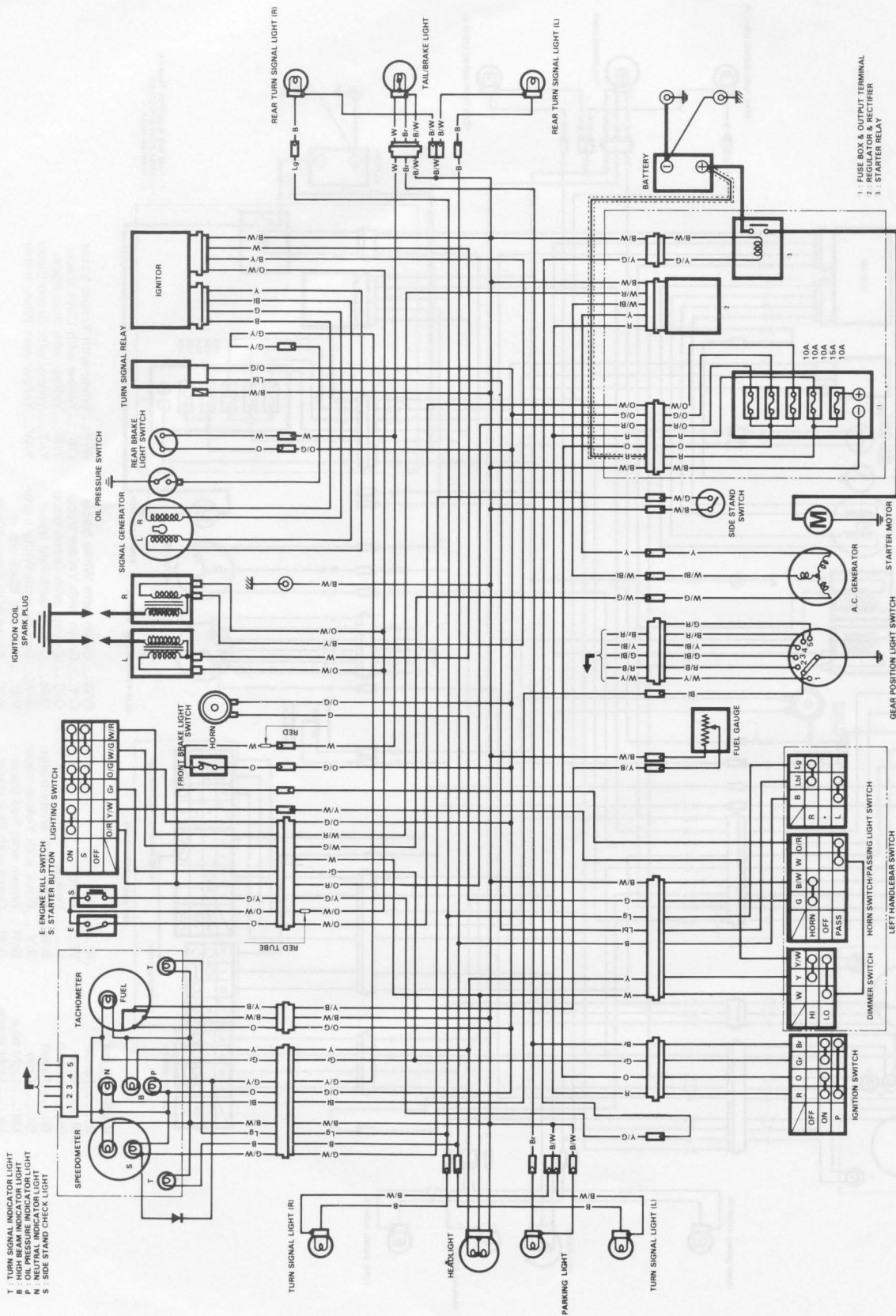

1: FUSE BOX & OUTPUT TERMINAL
 2: REGULATOR & RECTIFIER
 3: STARTER RELAY

- WIRE COLOR**
- BBlack
 - BlBlue
 - BrBrown
 - GGreen
 - GrGray
 - LblLight blue
 - LgLight green
 - OOrange
 - RRed
 - WWhite
 - YYellow
 - B/WBlack with White tracer
 - Br/YBrown with Yellow tracer
 - G/YGreen with Yellow tracer
 - O/GOrange with Green tracer
 - O/WOrange with White tracer
 - R/BRed with Black tracer
 - G/BlGreen with Blue tracer
 - G/RGreen with Red tracer
 - W/YWhite with Yellow tracer
 - Y/BYellow with Black tracer
 - Y/BlYellow with Blue tracer
 - Y/GYellow with Green tracer
 - Y/WYellow with White tracer

T: TURN SIGNAL INDICATOR LIGHT
 B: HIGH BEAM INDICATOR LIGHT
 P: OIL PRESSURE INDICATOR LIGHT
 S: SIDE STAND CHECK LIGHT

E: ENGINE KILL SWITCH
 S: STARTER BUTTON

ON OFF
 ON OFF
 ON OFF

ON OFF
 ON OFF
 ON OFF

ON OFF
 ON OFF
 ON OFF

ON OFF
 ON OFF
 ON OFF

ON OFF
 ON OFF
 ON OFF

ON OFF
 ON OFF
 ON OFF

ON OFF
 ON OFF
 ON OFF

ON OFF
 ON OFF
 ON OFF

ON OFF
 ON OFF
 ON OFF

ON OFF
 ON OFF
 ON OFF

ON OFF
 ON OFF
 ON OFF

ON OFF
 ON OFF
 ON OFF

ON OFF
 ON OFF
 ON OFF

ON OFF
 ON OFF
 ON OFF

ON OFF
 ON OFF
 ON OFF

ON OFF
 ON OFF
 ON OFF

ON OFF
 ON OFF
 ON OFF

ON OFF
 ON OFF
 ON OFF

ON OFF
 ON OFF
 ON OFF

ON OFF
 ON OFF
 ON OFF

ON OFF
 ON OFF
 ON OFF

ON OFF
 ON OFF
 ON OFF

ON OFF
 ON OFF
 ON OFF

ON OFF
 ON OFF
 ON OFF

ON OFF
 ON OFF
 ON OFF

ON OFF
 ON OFF
 ON OFF

ON OFF
 ON OFF
 ON OFF

ON OFF
 ON OFF
 ON OFF

ON OFF
 ON OFF
 ON OFF

ON OFF
 ON OFF
 ON OFF

ON OFF
 ON OFF
 ON OFF

ON OFF
 ON OFF
 ON OFF

ON OFF
 ON OFF
 ON OFF

ON OFF
 ON OFF
 ON OFF

ON OFF
 ON OFF
 ON OFF

ON OFF
 ON OFF
 ON OFF

ON OFF
 ON OFF
 ON OFF

ON OFF
 ON OFF
 ON OFF

ON OFF
 ON OFF
 ON OFF

ON OFF
 ON OFF
 ON OFF

ON OFF
 ON OFF
 ON OFF

ON OFF
 ON OFF
 ON OFF

ON OFF
 ON OFF
 ON OFF

ON OFF
 ON OFF
 ON OFF

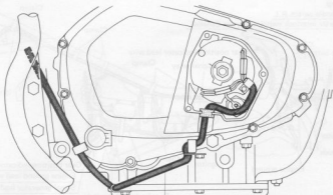

Signal generator lead wire

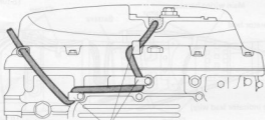

Clamp

Gear position indicator and neutral switch lead wire

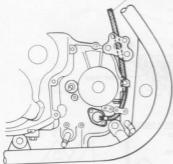

Clamp

Battery lead wire

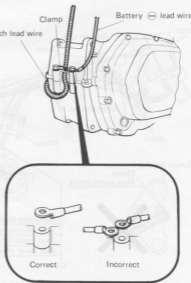

Correct

Incorrect

CABLE ROUTING

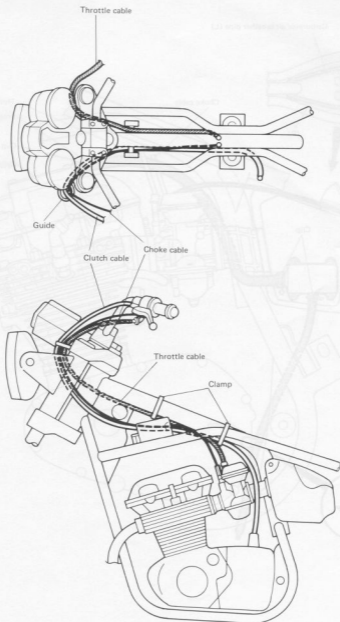

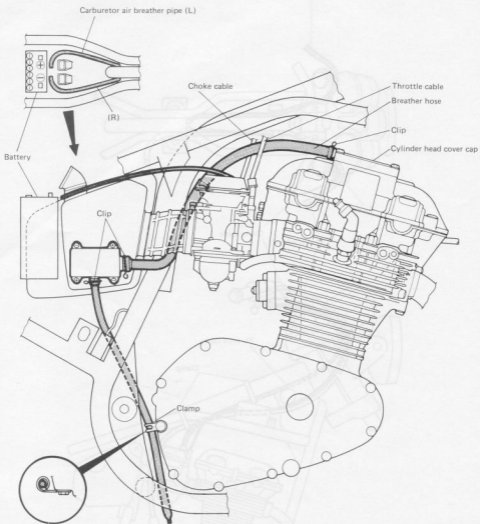

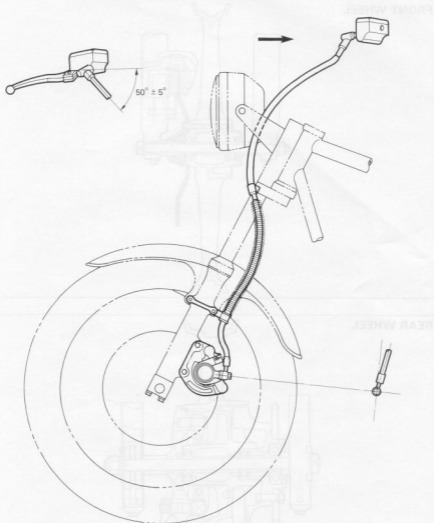
**CAUTION:**

1. Turning radius of the brake hose should be more than 30 mm at the center of brake hose.
2. Degrees of hose winding should be less than 15° at the length of 300 mm.
3. Do not fix the hoses of the caliper/master cylinder with extended condition.
4. Make sure that no protective part does not contact with the other parts.

FRONT WHEEL

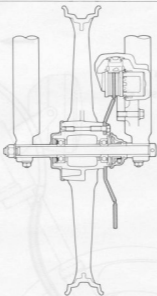

REAR WHEEL

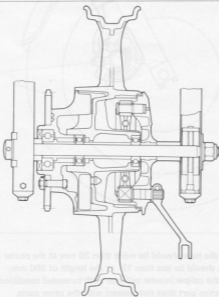

CAUTION

1. Turning radius of the trailer should be more than 30 mm at the center of brake line.
2. Degree of nose working should be less than 7 mm in a length of 300 mm.
3. Do not fit the base of the caliper/bushes in an untested condition.
4. Make sure that no protective part does not contact with other parts.

SPECIAL TOOLS

ITEM	PART NO.	PART NAME
1	09900-00302-015	8-mm T-type box wrench
	09900-06711	7-mm T-type box wrench
2	09900-00401	L-type hexagon wrench set (3, 4, 5, 6, 8, 10 mm)
3	09900-06105	Snap ring pliers (closing type)
4	09900-06107	Snap ring pliers (opening type)
5	09900-06108	Snap ring pliers (closing type)
6	09900-09003	Impact driver set
*7	09900-18720	14 mm hexagon wrench
8	09900-20102	Vernier calipers (200 mm)
9	09900-20202	Micrometer (25 – 50 mm)
	09900-20203	Micrometer (50 – 75 mm)
	09900-20204	Micrometer (75 – 100 mm)
	09900-20205	Micrometer (0 – 25 mm)
10	09900-20508	Cylinder gauge set
	09900-20509	75 mm rod
11	09900-20605	Dial calipers (10 – 34 mm, 1/100 mm)
12	09900-20606	Dial gauge (1/100 mm)
13	09900-20701	Magnetic stand
14	09900-20803	Thickness gauge
15	09900-20804	Thickness gauge
16	09900-20806	Thickness gauge
17	09900-21304	V-block (100 mm)
18	09900-22301	Plastigauge
19	09900-25002	Pocket tester
20	09900-28106	Electro tester
21	09900-28403	Hydrometer
22	09910-20116	Conrod holder
23	09910-34510	Piston pin puller
24	09911-73730	T-type hexagon wrench (5 mm)
	09914-25811	T-type hexagon wrench (6 mm)
25	09911-94530	Valve guide installer attachment
26	09912-34510	Crankcase separating tool
27	09913-13121	Carburetor balancer
	09913-13140	Adaptor
28	09913-14541	Fuel level gauge set
29	09913-75520	Bearing installer
30	09913-80112	Bearing remover
31	09915-64510	Compression gauge
32	09915-63210	Adaptor
33	09915-74510	Oil pressure gauge
34	09915-77330	Gauge (0 – 10 kg/cm ²)
35	09916-14510	Valve lifter

ITEM	PART NO.	PART NAME
36	09916-24900	Valve seat cutter set
*37	09916-24490	Cutter head (N-233)
	09916-24430	Cutter blade (shorter blade N-553)
38	09916-34520	(A) 7 mm reamer
	09916-34530	(B) 12.2 mm reamer
	09916-34540	(C) Reamer handle
39	09916-44511	Valve guide remover
40	09916-54531	Installer attachment
41	09916-57321	Valve guide installer handle
42	09916-64510	Tappet depressor
43	09916-74520	Piston ring compressor holder body
	09916-74540	Band (Bore: 63 – 75 mm)
44	09916-84510	Tweezers
*45	09920-53721	Clutch sleeve hub holder
46	09923-74510	Bearing puller (20 – 38 mm)
47	09924-84510	Bearing installer set
48	09930-30102	Rotor remover shaft
	09930-33710	Attachment
49	09930-14511	Cylinder head nut and spark plug wrench set
	(A) 09914-24510 T-handle	
	(B) 09911-74510 Long socket (14-mm)	
	(C) 09911-74520 Long socket (12-mm)	
	(D) 09930-14530 Universal joint	
	(E) 09930-14520 Spark plug wrench (21 mm)	
50	09930-13210	Spark plug socket wrench (18 mm)
51	09930-44911	Rotor holder
52	09940-14911	Steering nut socket wrench
53	09940-34520	T-handle
54	09940-34530	Attachment A
55	09940-50112	Front fork oil seal installer
56	09940-60113	Spoke nipple wrench
57	09941-34513	Swing arm bearing installer set
58	09941-44910	Swing arm bearing remover
59	09941-54911	Steering race remover
60	09941-74910	Steering bearing installer
61	09941-84510	Bearing remover
62	09943-74111	Front fork oil level gauge

* Asterisk mark indicates the exclusive tool for GR650

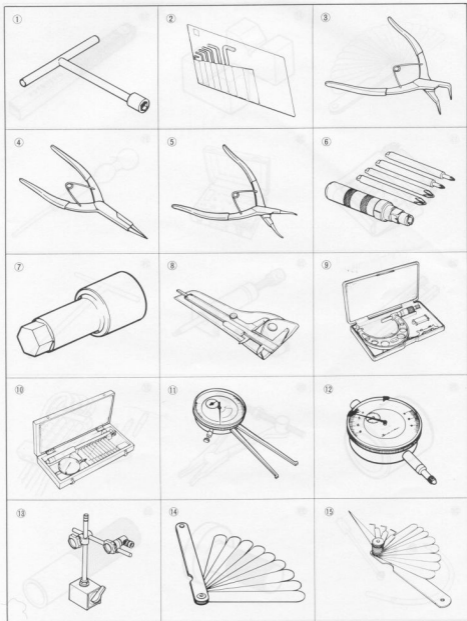

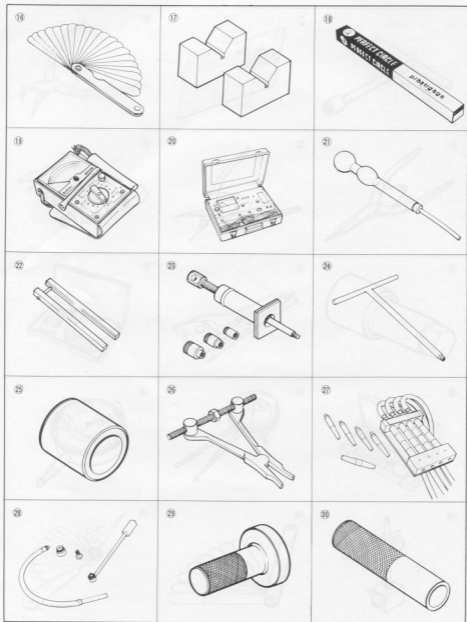



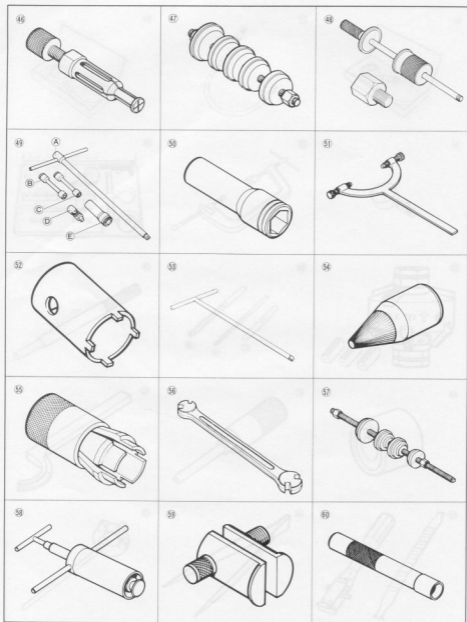

TIGHTENING TORQUE

ENGINE

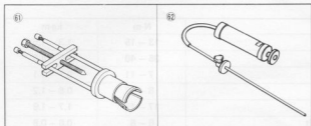

ITEM	DESCRIPTION	Torque (ft-lb)	Torque (N-m)
	Washer mounting bolt	40 - 50	40 - 50
	Washer connector clamp bolt	4 - 7	4 - 7
	Washer pipe bolt	30 - 38	30 - 38
	Engine mounting bracket bolt	30 - 30	30 - 30
	Lower nut	58 - 68	58 - 68
	Lower nut	80 - 73	80 - 73
	Lower nut	50 - 73	50 - 73
	Upper nut	63 - 50	63 - 50
	Engine bracket nut	100 - 130	100 - 130
	5 mm	20 - 24	20 - 24
	5 mm	9 - 13	9 - 13
	Control bolt	0.2 - 1.2	0.2 - 1.2
	Oil pressure regulator	13 - 20	13 - 20
	Oil pan bolt	8 - 12	8 - 12
	Oil drain plug nut	40 - 60	40 - 60
	Oil drain plug nut	8 - 12	8 - 12
	Oil pump flange bolt	3 - 9	3 - 9
	7-pin sensor housing	18 - 28	18 - 28
	Oil filter - seal	13 - 13	13 - 13
	Light sensor bolt	18 - 28	18 - 28
	Control nut	48 - 54	48 - 54
	Control sensor bolt	30 - 40	30 - 40
	Control between coil gear bolt	8 - 12	8 - 12
	Primary drive gear nut	80 - 110	80 - 110
	Hydraulic drive bolt	18 - 28	18 - 28
	Generator rotor bolt	180 - 190	180 - 190
	Generator rotor bolt	160 - 170	160 - 170

TIGHTENING TORQUE

ENGINE

ITEM		N-m	kg-m
Cylinder head cover bolt		13 – 15	1.3 – 1.5
Cylinder head nut		35 – 40	3.5 – 4.0
Cylinder head bolt		7 – 11	0.7 – 1.1
Camshaft journal holder bolt		8 – 12	0.8 – 1.2
Cam sprocket bolt		17 – 19	1.7 – 1.9
Cam chain tensioner adjuster bolt		6 – 8	0.6 – 0.8
Generator rotor bolt		150 – 170	15.0 – 17.0
Flywheel allen bolt		15 – 20	1.5 – 2.0
Primary drive gear nut		90 – 110	9.0 – 11.0
Counter balancer drive gear bolt		8 – 12	0.8 – 1.2
Counter balancer center bolt		35 – 45	3.5 – 4.5
Conrod nut		48 – 54	4.8 – 5.4
Signal generator bolt		18 – 28	1.8 – 2.8
Oil pressure switch		13 – 17	1.3 – 1.7
Neutral stopper housing		18 – 28	1.8 – 2.8
Oil pump fitting bolt		7 – 9	0.7 – 0.9
Clutch spring bolt		8 – 12	0.8 – 1.2
Clutch sleeve hub nut		40 – 60	4.0 – 6.0
Oil pan bolt		8 – 12	0.8 – 1.2
Oil pressure regulator		17 – 20	1.7 – 2.0
Crankcase bolt	6 mm	9 – 13	0.9 – 1.3
	8 mm	20 – 24	2.0 – 2.4
Engine sprocket nut		100 – 130	10.0 – 13.0
Engine mounting bolt	Upper front	67 – 80	6.7 – 8.0
	Lower	60 – 72	6.0 – 7.2
	Lower rear	60 – 72	6.0 – 7.2
	Upper rear	55 – 66	5.5 – 6.6
Engine mounting bracket bolt		20 – 30	2.0 – 3.0
Exhaust pipe bolt		20 – 25	2.0 – 2.5
Muffler connector clamp bolt		4 – 7	0.4 – 0.7
Muffler mounting bolt		40 – 60	4.0 – 6.0

CHASSIS

ITEM		N-m	kg-m
Front axle nut		36 – 52	3.6 – 5.2
Front axle holder nut		15 – 25	1.5 – 2.5
Front fork damper rod bolt		15 – 25	1.5 – 2.5
Disc plate bolt		15 – 25	1.5 – 2.5
Spoke nipple		4 – 5	0.4 – 0.5
Caliper mounting bolt		25 – 40	2.5 – 4.0
Caliper axle bolt		15 – 20	1.5 – 2.0
Air bleeder valve		6 – 9	0.6 – 0.9
Front fork air valve		4 – 7	0.4 – 0.7
Front fork upper clamp bolt		20 – 30	2.0 – 3.0
Front fork lower clamp bolt		15 – 25	1.5 – 2.5
Handlebar clamp bolt		12 – 20	1.2 – 2.0
Handlebar clamp mounting bolt		40 – 60	4.0 – 6.0
Brake hose union bolt		20 – 25	2.0 – 2.5
Master cylinder clamp bolt		5 – 8	0.5 – 0.8
Steering stem clamp bolt		15 – 25	1.5 – 2.5
Steering stem head bolt		20 – 30	2.0 – 3.0
Steering stem nut		40 – 60	4.0 – 6.0
Brake pedal arm bolt		10 – 15	1.0 – 1.5
Brake cam lever bolt		5 – 8	0.5 – 0.8
Front footrest bolt		27 – 43	2.7 – 4.3
Rear footrest bolt		15 – 25	1.5 – 2.5
Rear torque link nut		20 – 30	2.0 – 3.0
Rear sprocket mounting bolt		40 – 60	4.0 – 6.0
Rear shock absorber mounting nut (Upper and lower)		48 – 72	4.8 – 7.2
Rear cushion rod bolt (Upper and lower)		70 – 100	7.0 – 10.0
Rear cushion lever nut		70 – 100	7.0 – 10.0
Rear shock absorber bracket nut		70 – 100	7.0 – 10.0
Swing arm pivot shaft	Nut	54 – 84	5.4 – 8.4
	Shaft	55 – 85	5.5 – 8.5
Rear axle nut		50 – 80	5.0 – 8.0

TIGHTENING TORQUE CHART

For other bolts and nuts not listed, refer to this chart:

Bolt Diameter (A) (mm)	Conventional or "4" marked bolt		"7" marked bolt	
	kg-m	N-m	kg-m	N-m
4	0.1 - 0.2	1.0 - 2.0	0.15 - 0.3	1.5 - 3.0
5	0.2 - 0.4	2.0 - 4.0	0.3 - 0.6	3.0 - 6.0
6	0.4 - 0.7	4.0 - 7.0	0.8 - 1.2	8.0 - 12.0
8	1.0 - 1.6	10.0 - 16.0	1.8 - 2.8	18.0 - 28.0
10	2.2 - 3.5	22.0 - 35.0	4.0 - 6.0	40.0 - 60.0
12	3.5 - 5.5	35.0 - 55.0	7.0 - 10.0	70.0 - 100.0
14	5.0 - 8.0	50.0 - 80.0	11.0 - 16.0	110.0 - 160.0
16	8.0 - 13.0	80.0 - 130.0	17.0 - 25.0	170.0 - 250.0
18	13.0 - 19.0	130.0 - 190.0	20.0 - 28.0	200.0 - 280.0



Conventional bolt



"4" Marked bolt



"7" Marked bolt

SERVICE DATA

VALVE + GUIDE

Unit: mm

ITEM		STANDARD	LIMIT
Valve diam.	IN.	40.0	—
	EX.	34.0	—
Valve lift	IN.	8.5	—
	EX.	8.0	—
Tappet clearance (when cold)	IN. & EX.	0.03–0.08	—
Valve guide to valve stem clearance	IN.	0.025–0.055	0.35
	EX.	0.040–0.070	0.35
Valve guide I.D.	IN. & EX.	7.000–7.015	—
Valve stem O.D.	IN.	6.960–6.975	—
	EX.	6.945–6.960	—
Valve stem runout	IN. & EX.	—	0.05
Valve head thickness	IN. & EX.	—	0.5
Valve stem end length	IN. & EX.	—	4.0
Valve seat width	IN. & EX.	1.0–1.2	—
Valve head radial runout	IN. & EX.	—	0.03
Valve spring free length (IN. & EX.)	INNER	—	35.9
	OUTER	—	40.1
Valve spring tension (IN. & EX.)	INNER	9.9–11.7 kg at length 31.0 mm	—
	OUTER	20.6–24.2 kg at length 35.0 mm	—

CAMSHAFT + CYLINDER HEAD

Unit: mm

ITEM	STANDARD		LIMIT
Cam height	IN.	37.270–37.310	36.970
	EX.	37.270–37.310	36.970
Camshaft journal oil clearance	IN. & EX.	0.032–0.066	0.150
Camshaft journal holder I.D.	IN. & EX.	22.012–22.025	—
Camshaft journal O.D.	IN. & EX.	21.959–21.980	—
Cam chain 20-pitch length	—		128.9
Cam chain pin (at arrow "3")	24th pin		—
Cylinder head distortion	—		0.10

CYLINDER + PISTON + PISTON RING

Unit: mm

ITEM	STANDARD		LIMIT	
Compression pressure	11–15 kg/cm ²		9 kg/cm ²	
Compression pressure difference	—		2 kg/cm ²	
Piston to cylinder clearance	0.050–0.060		0.120	
Cylinder bore	77.000–77.015		77.080	
Piston diam.	76.945–76.960 Measure at 15° from the skirt end.		76.880	
Cylinder distortion	—		0.10	
Piston ring free end gap	1st	N	Approx. 7.0	5.6
		R	Approx. 5.9	4.7
	2nd	N	Approx. 10.0	8.0
		R	Approx. 9.6	7.7
Piston ring end gap	1st	0.10–0.30	0.70	
	2nd	0.10–0.30	0.70	
Piston ring to groove clearance	1st	—	0.18	
	2nd	—	0.15	
Piston ring groove width	1st	1.01–1.03	—	
	2nd	1.21–1.23	—	
	Oil	2.51–2.53	—	
Piston ring thickness	1st	0.970–0.990	—	
	2nd	1.170–1.190	—	
Piston pin bore	18.002–18.008		18.030	
Piston pin O.D.	17.996–18.000		17.980	

CONROD + CRANKSHAFT + BALANCER

Unit: mm

ITEM	STANDARD	LIMIT
Conrod small end I.D.	18.006—18.014	18.040
Conrod big end side clearance	0.10—0.20	0.30
Conrod big end width	23.95—24.00	—
Crank pin width	24.10—24.15	—
Conrod big end oil clearance	0.024—0.048	0.080
Crank pin O.D.	35.976—36.000	—
Crankshaft journal oil clearance	0.020—0.044	0.080
Crankshaft journal O.D.	35.976—36.000	—
Crankshaft thrust bearing thickness	2.860—3.020	2.70
Crankshaft thrust clearance	0.080—0.120	—
Crankshaft journal holder width	54.96—55.04	—
Crankshaft journal width	58.00—58.08	—
Crankshaft runout	—	0.05
Balancer journal oil clearance	0.020—0.044	0.080
Balancer journal O.D.	31.984—32.000	—
Balancer thrust clearance	0.045—0.100	—
Balancer thrust bearing thickness	2.900—3.025	2.75
Balancer journal holder width	16.95—17.03	—
Balancer journal width	20.00—20.05	—

OIL PUMP

ITEM	STANDARD	LIMIT
Oil pump reduction ratio	1.717 (72/32 x 29/38)	—
Oil pressure (at 60°C, 140°F)	Above 2.5 kg/cm ² Below 5.5 kg/cm ² at 3 000 r/min.	—

CLUTCH

Unit: mm

ITEM		STANDARD	LIMIT
Clutch cable play		4	—
Clutch release screw		1/4 turn back	—
Drive plate thickness	No. 1	2.92–3.08	2.6
	No. 2	3.45–3.55	3.2
Drive plate claw width		15.9–16.0	15.1
Driven plate thickness		1.40 ± 0.05	—
Driven plate distortion		—	0.10
Clutch spring free length		—	34.0

TRANSMISSION + DRIVE CHAIN

Unit: mm Except ratio

ITEM		STANDARD	LIMIT
Primary reduction ratio		2.250 (72/32)	—
Final reduction ratio		2.533 (38/15)	—
Gear ratios	Low	2.846 (37/13)	—
	2nd	1.812 (29/16)	—
	3rd	1.368 (26/19)	—
	4th	1.142 (24/21)	—
	Top	1.000 (22/22)	—
Shift fork to groove clearance		0.10–0.30	0.50
Shift fork groove width		5.50–5.60	—
Shift fork thickness		5.30–5.40	—
Countershaft length (Low to 2nd)		117 ± _{0.1} ⁰	—
Drive chain	Type	D.I.D.: DID 50HL TAKASAGO: RK50GO	
	Links	106 links	
	20 pitch length	—	319.4
Drive chain slack		10–20	—

CARBURETOR

ITEM	SPECIFICATION	
	The others	only for E-18
Carburetor type	MIKUNI BS36SS	
Bore size	36 mm	
I.D. No.	15500	15520
Idle r/min.	1 300 ± 50 r/min.	←
Fuel level	5.0 ± 0.5 mm	
Float height	23.0 ± 1.0 mm	
Main jet (M.J.)	# 130	
Main air jet (M.A.J.)	0.6	
Jet needle (J.N.)	5C08-3rd	
Needle jet (N.J.)	Y-8	
Throttle valve (T.V.)	# 90	
Pilot jet (P.J.)	# 42.5	
By pass (B.P.)	0.9, 0.9, 1.3 mm	
Pilot outlet (P.O.)	1.3 mm	
Valve seat (V.S.)	2.0 mm	
Starter jet (G.S.)	# 30	
Pilot screw (P.S.)	PRE-SET (3.0)	
Pilot air jet (P.A.J.)	# 130	
Throttle cable play	0.5 – 1.0 mm	←
Choke cable play	0.5 – 1.0 mm	←

ELECTRICAL

Unit: mm

ITEM	SPECIFICATION		NOTE
Ignition timing	15° B.T.D.C. Below 1 650 ± 100 r/min and 35° B.T.D.C. Above 3 000 ± 100 r/min.		
Firing order	R · L		
Spark plug	Type	NGK: D8EA or N.D.: X24ES-U	E1,24,25,34
	Gap	0.6–0.7	
	Type	NGK:DR8ES-L or N.D.:X24ESR-U	The others
	Gap	0.6–0.7	
Spark performance	Over 8 at 1 atm		
Signal coil resistance	450–650 Ω		B-G, BI-Y
Ignition coil resistance	Primary	⊕ tap – ⊖ tap 3–5 Ω	
	Secondary	Plug cap – ⊕ tap 20–30 kΩ	
Generator no-load voltage	More than 80 V (AC) at 5 000 r/min.		
Regulated voltage	13.5–15.5 V at 5 000 r/min.		
Generator coil resistance	0–1 Ω		
Starter motor	Brush length	Limit: 6	MITSUBA
	Commutator under-cut	Limit: 0.2	
Starter relay resistance	3–4 Ω		Y/G-B/W
Battery	Type designation	YB14L–A2	
	Capacity	12V50.4kC(14Ah)/10HR	
	Standard electrolyte S.G.	1.28 at 20°C (68°F)	
Fuse size	HEAD	10 A	
	SIGNAL	10 A	
	IGNITION	10 A	
	MAIN	15 A	
	POWER SOURCE	10 A	

BRAKE + WHEEL

Unit: mm

ITEM		STANDARD	LIMIT
Rear brake pedal free travel		20-30	—
Rear brake pedal height		25-35	—
Brake drum I.D.	Rear	—	160.7
Brake lining thickness		—	1.5
Brake disc thickness	Front	5.0 ± 0.2	4.5
Brake disc runout		—	0.30
Master cylinder bore	Front	14.000-14.043	—
Master cylinder piston diam.	Front	13.968-13.941	—
Brake caliper cylinder bore	Front	42.860-42.899	—
Brake caliper piston diam.	Front	42.785-42.810	—
Wheel rim runout	Axial	—	2.0
	Radial	—	2.0
Wheel axle runout	Front	—	0.25
	Rear	—	0.25
Tire size	Front	100/90-19 57H	—
	Rear	130/90-16 67H	—
Tire tread depth	Front	—	1.6
	Rear	—	2.0

SUSPENSION

Unit: mm

ITEM	STANDARD	LIMIT	NOTE
Front fork stroke	140	—	
Front fork spring free length	—	520	
Front fork oil level	125.3	—	only for E-28 cast wheel model
	170	—	The others
Front fork air pressure	50 kPa 0.5 kg/cm ²	—	only for E-28 cast wheel model
Rear wheel travel	110	—	
Swing arm pivot shaft runout	—	0.3	

FUEL + OIL

ITEM	SPECIFICATION	NOTE
Fuel type	Gasoline used should be graded 85-95 octane or higher. An unleaded or low-lead gasoline type is recommended.	
Fuel tank including reserve	12.0 L	
	reserve 2.5 L	
Engine oil type	SAE 10W/40, API SE or SF	
Engine oil capacity	Change 2 400 ml	
	Filter change 2 800 ml	
	Overhaul 3 000 ml	
Front fork oil type	Fork oil # 15	
Front fork oil capacity (each leg)	263 ml	only for E-28 cast wheel model
	235 ml	The others
Brake fluid type	SAE J1703, DOT3 or DOT4	

TIRE PRESSURE

COLD INFLATION TIRE PRESSURE	SOLO RIDING		DUAL RIDING	
	kPa	kg/cm ²	kPa	kg/cm ²
FRONT	200	2.00	200	2.00
REAR	225	2.25	250	2.50

WATTAGE

Unit: W

ITEM		SPECIFICATION			
		E-01X,06X,24X, 28X	E-01,06,24,28	E-02,04,15,17, 21,25,34,39	E-16,18,22,26
Headlight	HI	60	←	←	←
	LO	55	←	←	←
Parking or position light			4	←	←
Tail/Brake light		8/23	←	5/21	←
Turn signal light		23	←	21	←
Speedometer light		1.7	←	←	←
Tachometer light		1.7	←	←	←
Turn signal indicator light		3.4	←	←	←
High beam indicator light		1.7	←	←	←
Neutral indicator light		3.4	←	←	←
Oil pressure indicator light		3.4	←	←	←
Gear position indicator light		1.12	←	←	←
Side stand check light		3.4	←	←	

X: Spoke wheel model

Prepared by

SUZUKI MOTOR CO.,LTD.

Administration Department
Overseas Service Division

February, 1983

Manual No.: 99500-36030-01E (英)

Printed in Japan

SUZUKI MOTOR CO., LTD.

S

Printed in Japan 75